

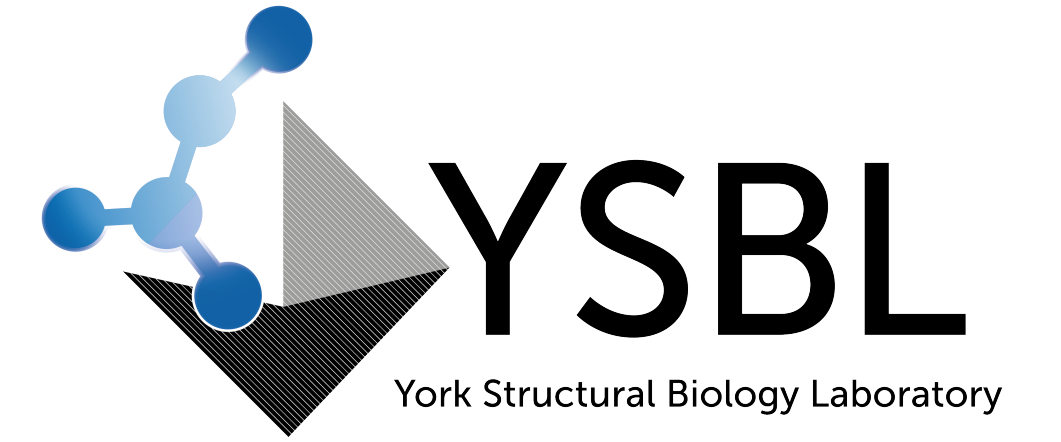

UNIVERSITY
of York



Privateer

Ickniel Workshop 2024

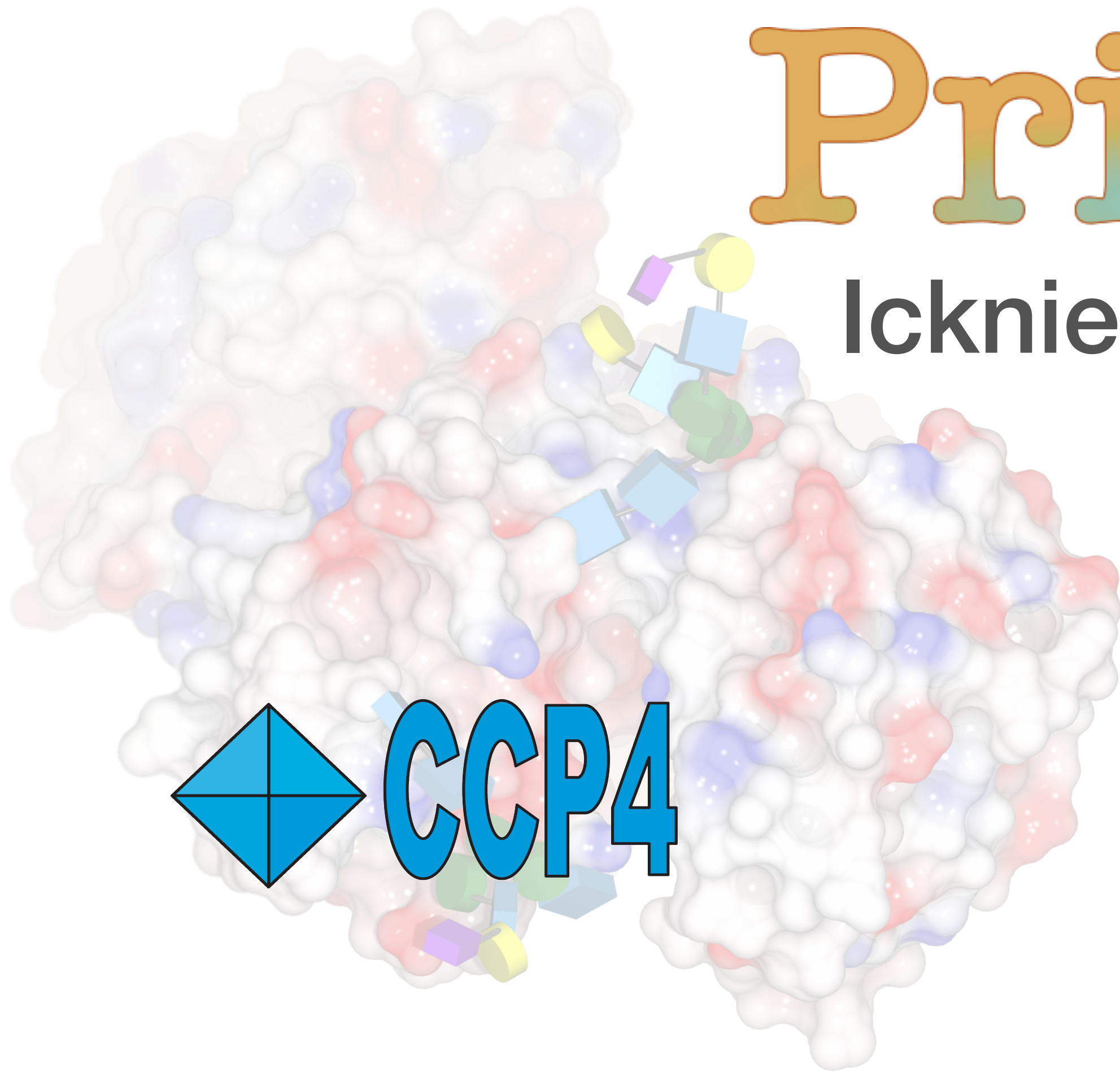

Lou Holland and Pham Phuong Thao
Glycojones Team
York Structural Biology Laboratory

Protein glycosylation



glyco-
/'glɪkəʊ/

GREEK

glukus → glyco-

Sweet

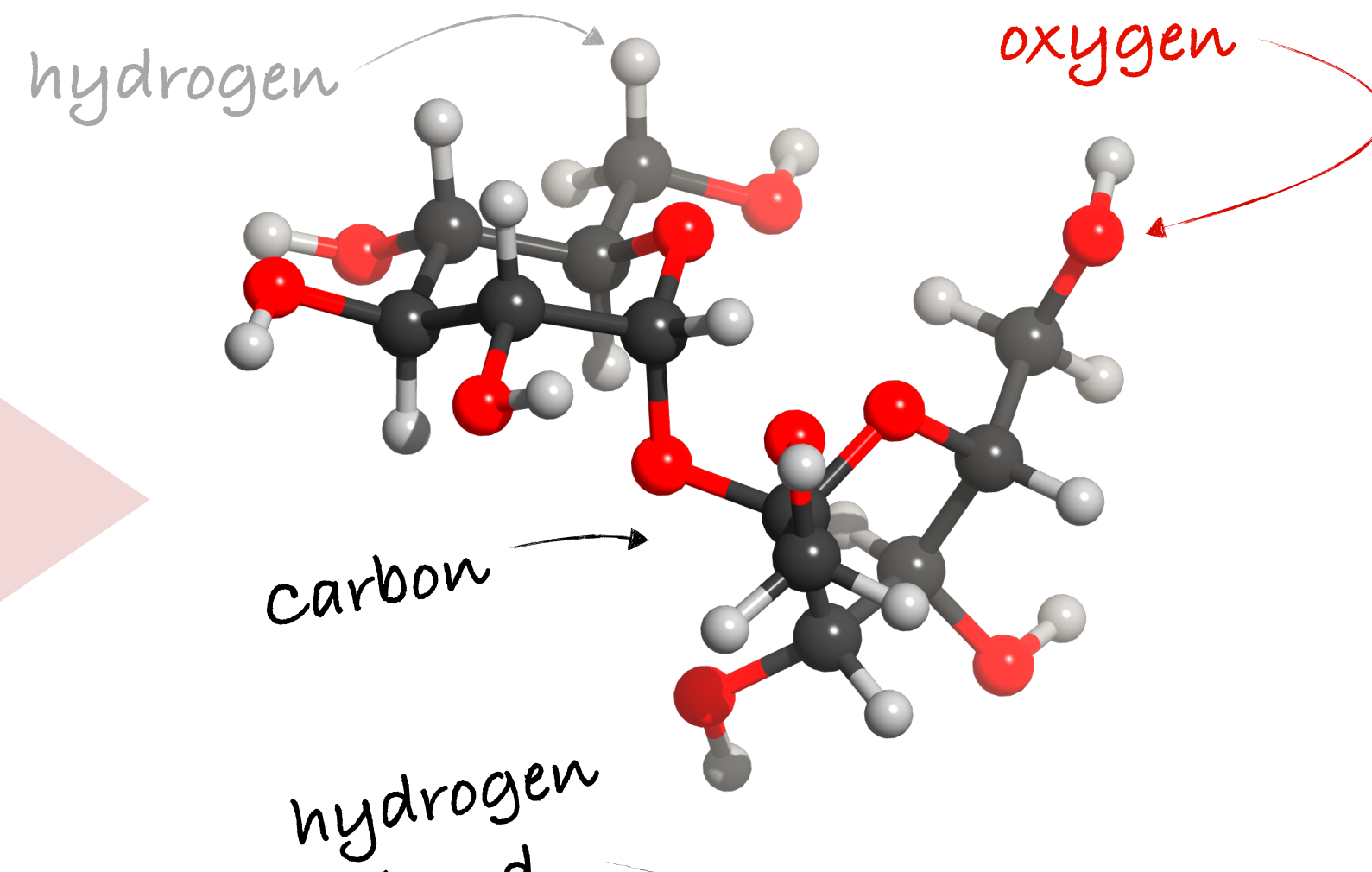
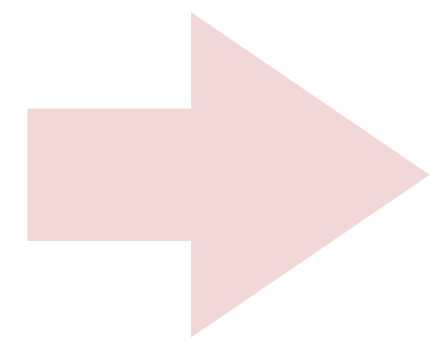

Not always sweet!

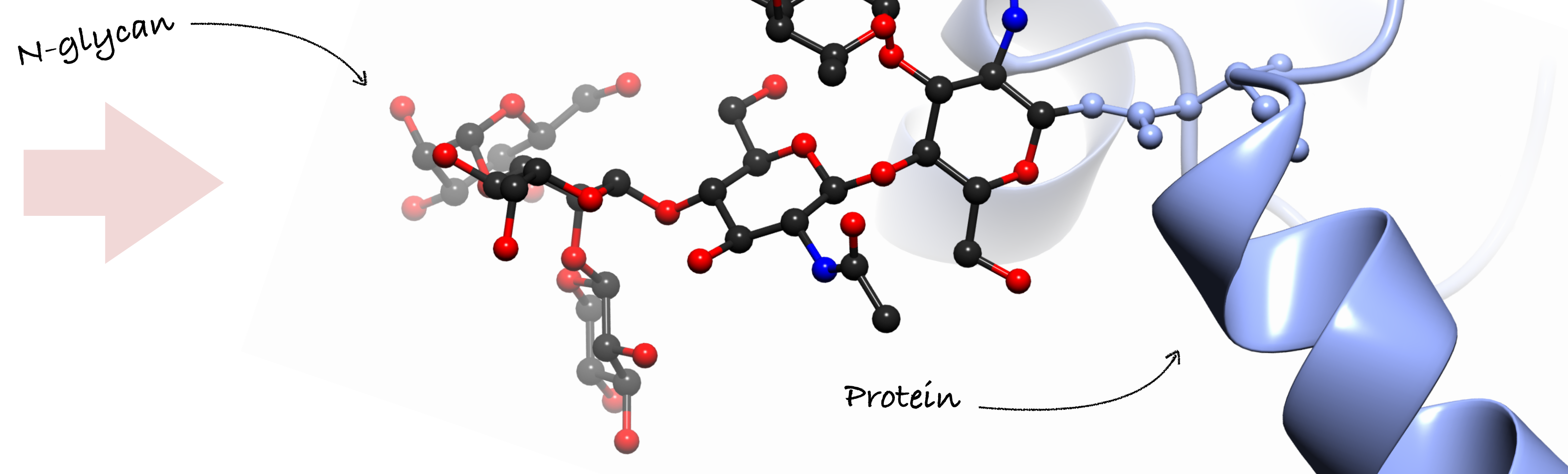
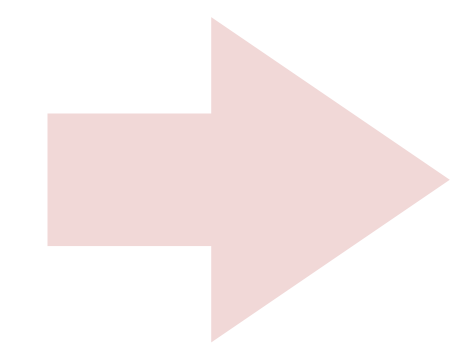
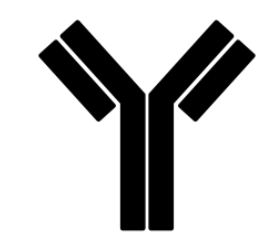
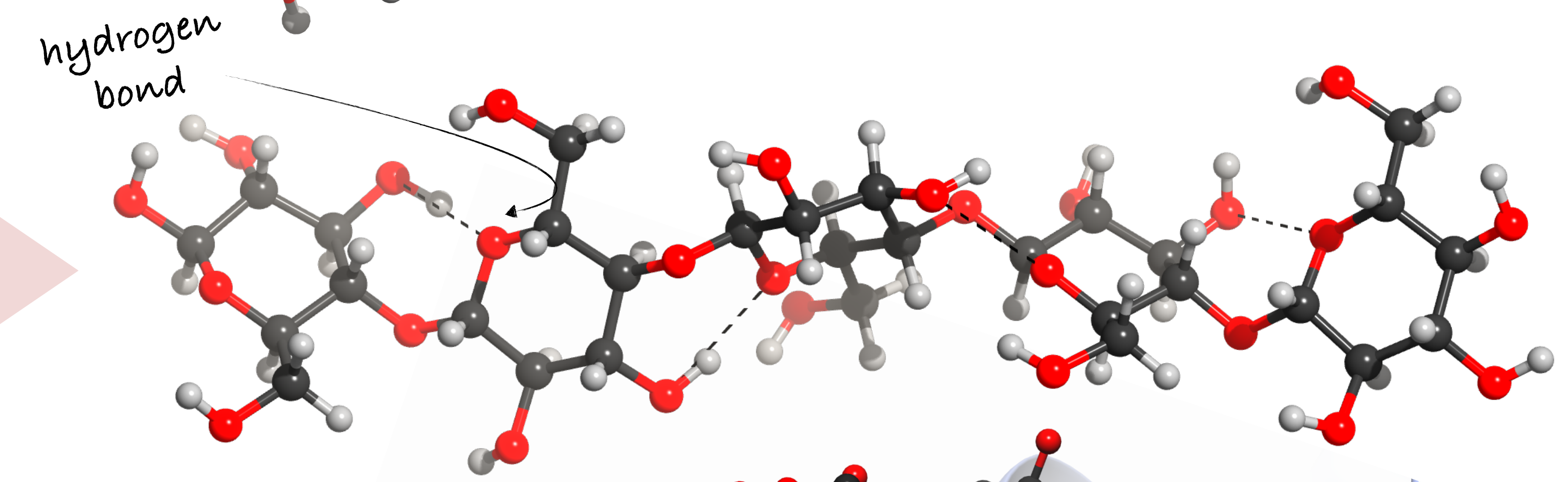
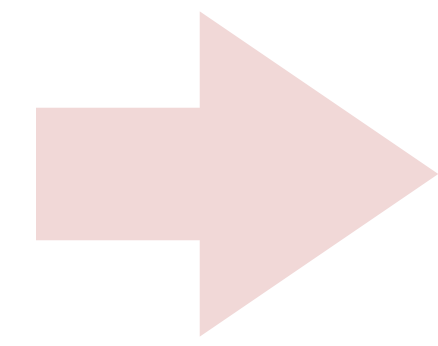

Protein glycosylation

1 nm

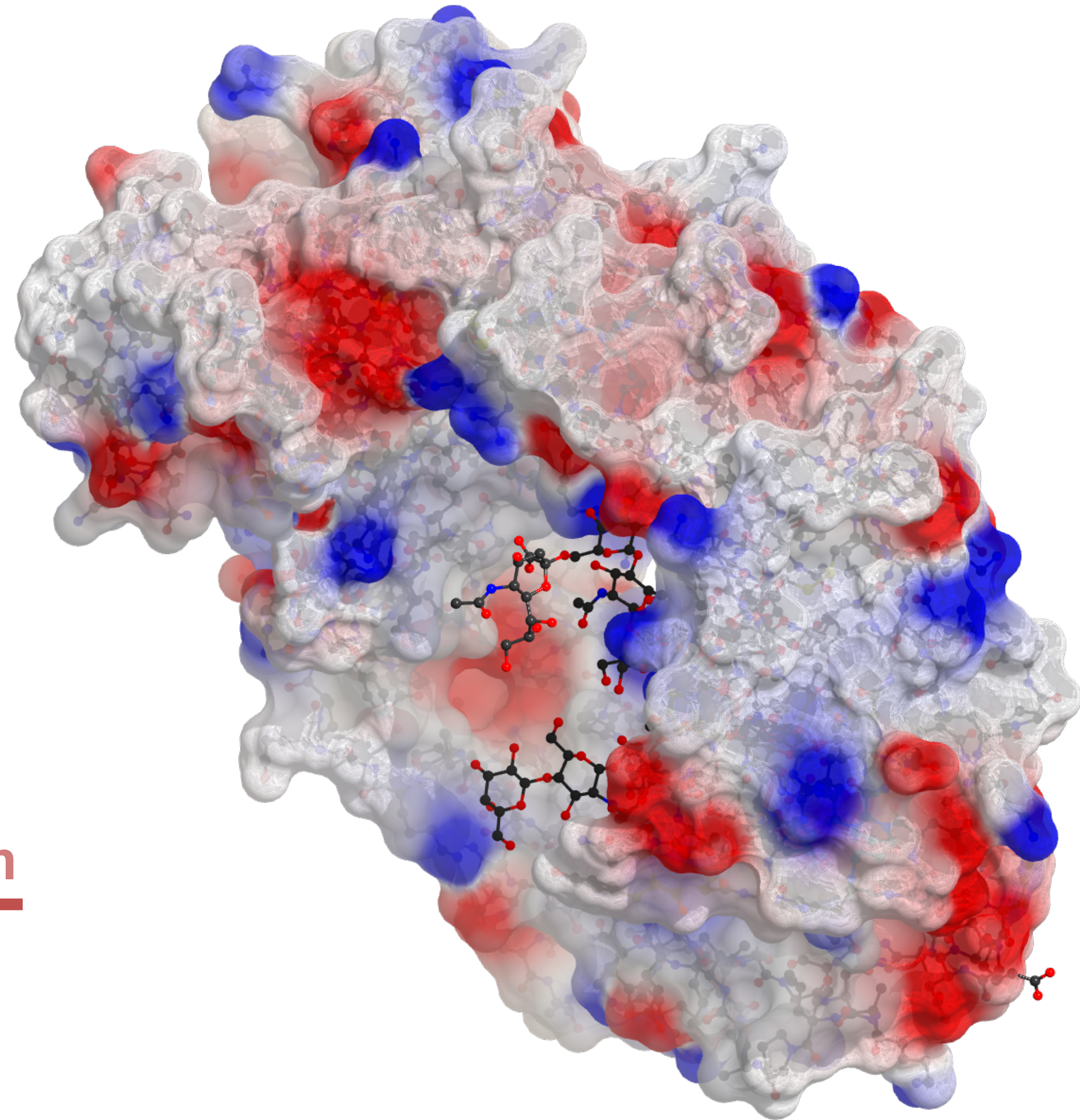

Protein glycosylation

1 nm



Protein glycosylation

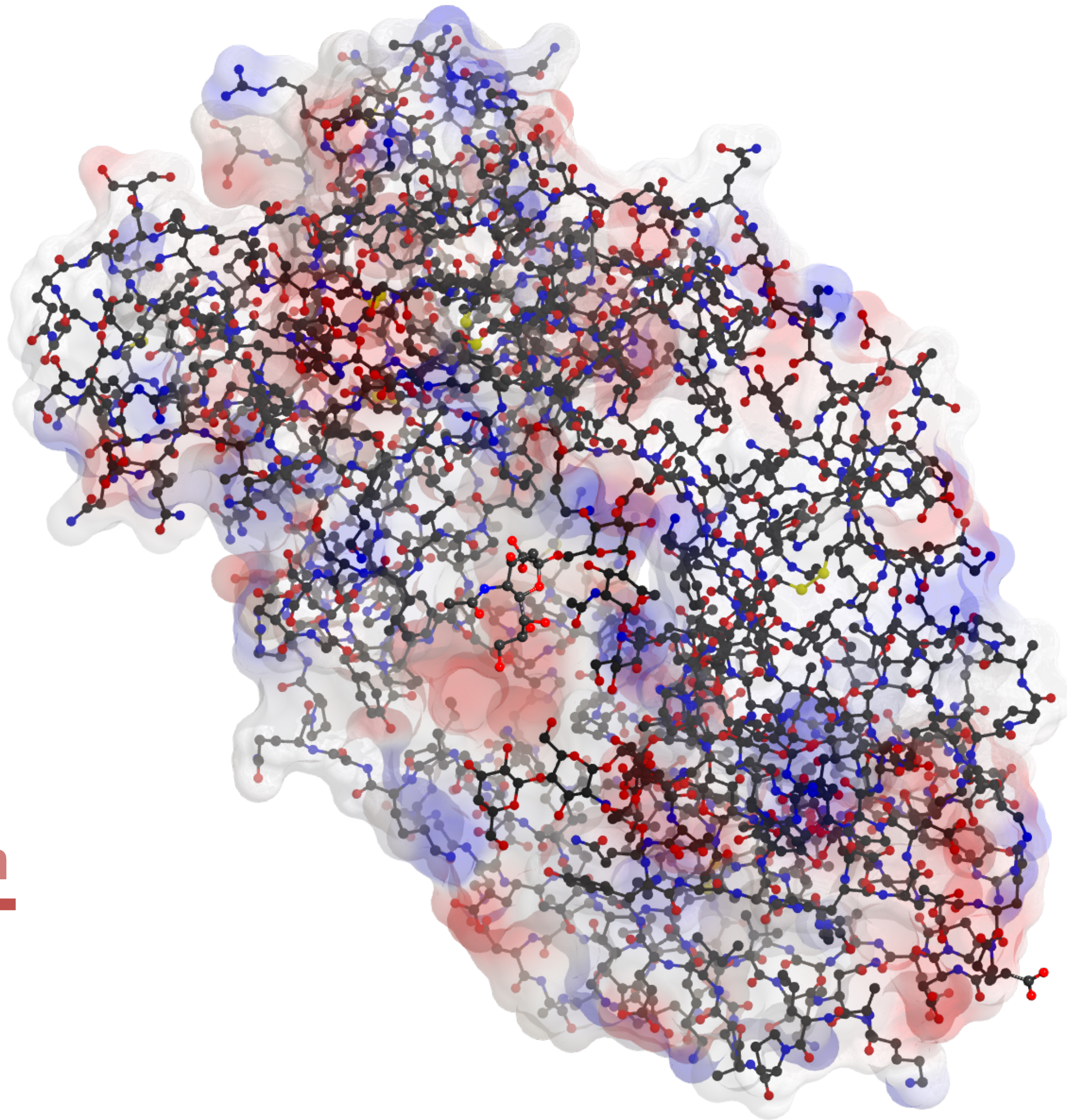

1 nm

Co-translational

Post-translational

OST-A

OST-B

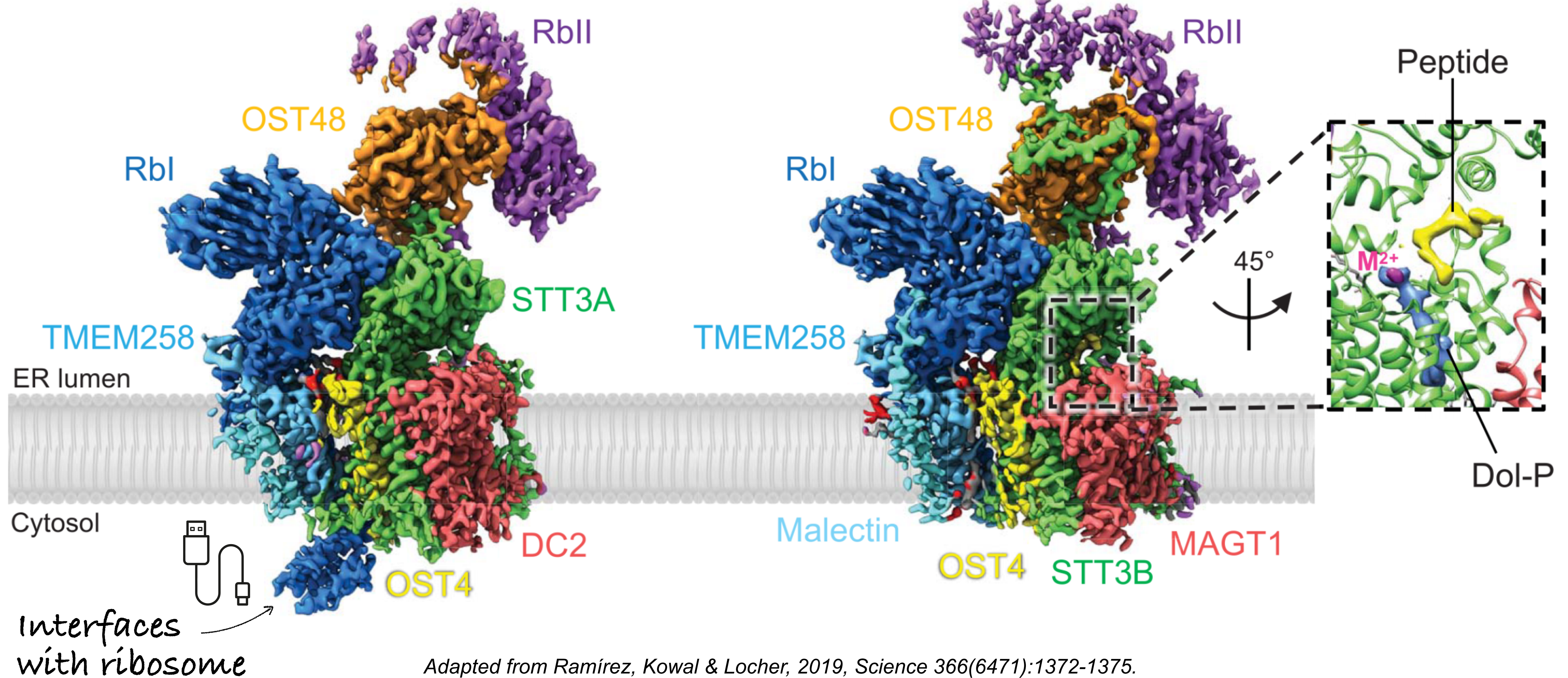

Adapted from Ramírez, Kowal & Locher, 2019, *Science* 366(6471):1372-1375.

Protein glycosylation

N-glycans

Consensus sequence (sequon)
Asn – not Pro – Ser/Thr

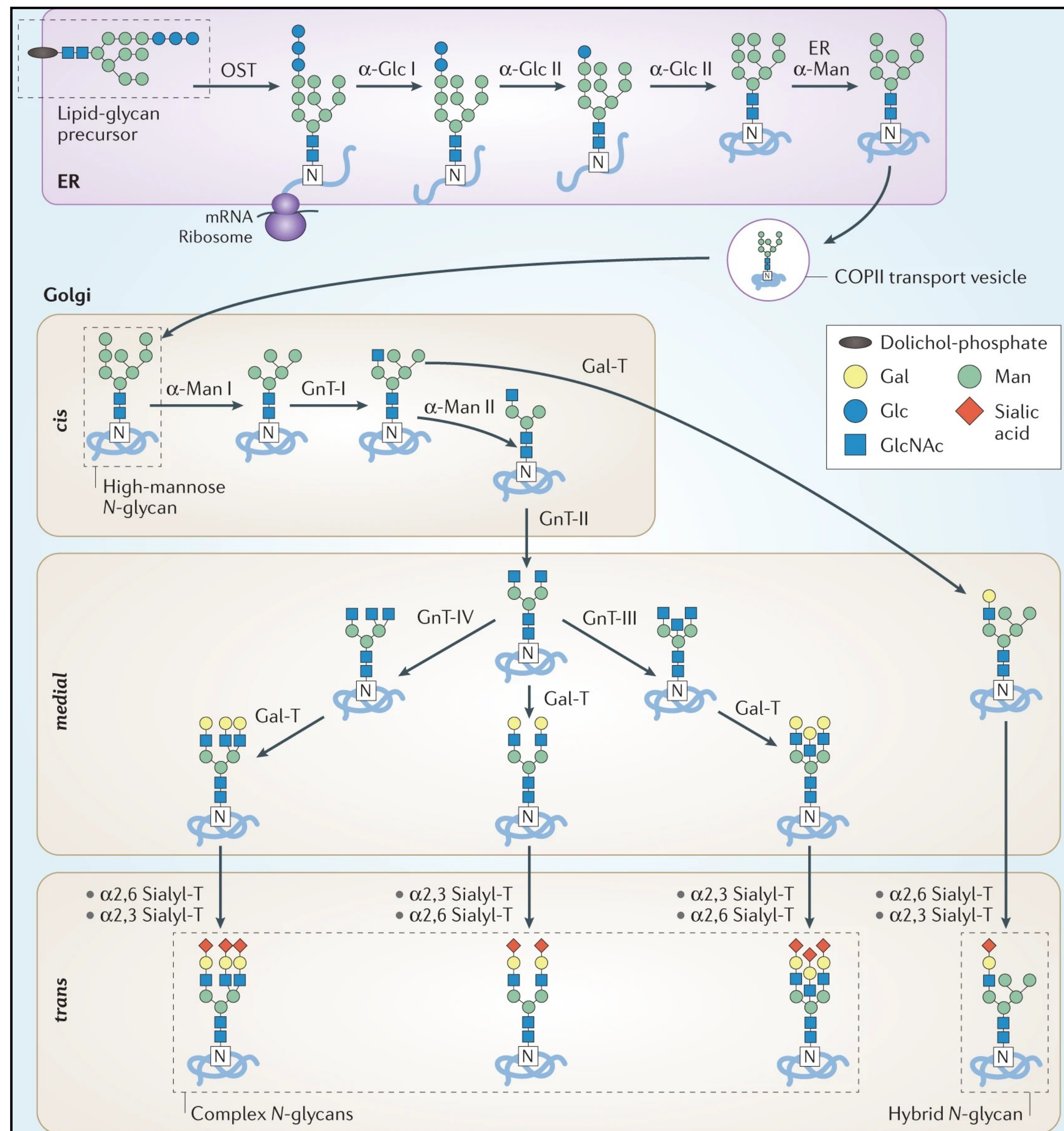

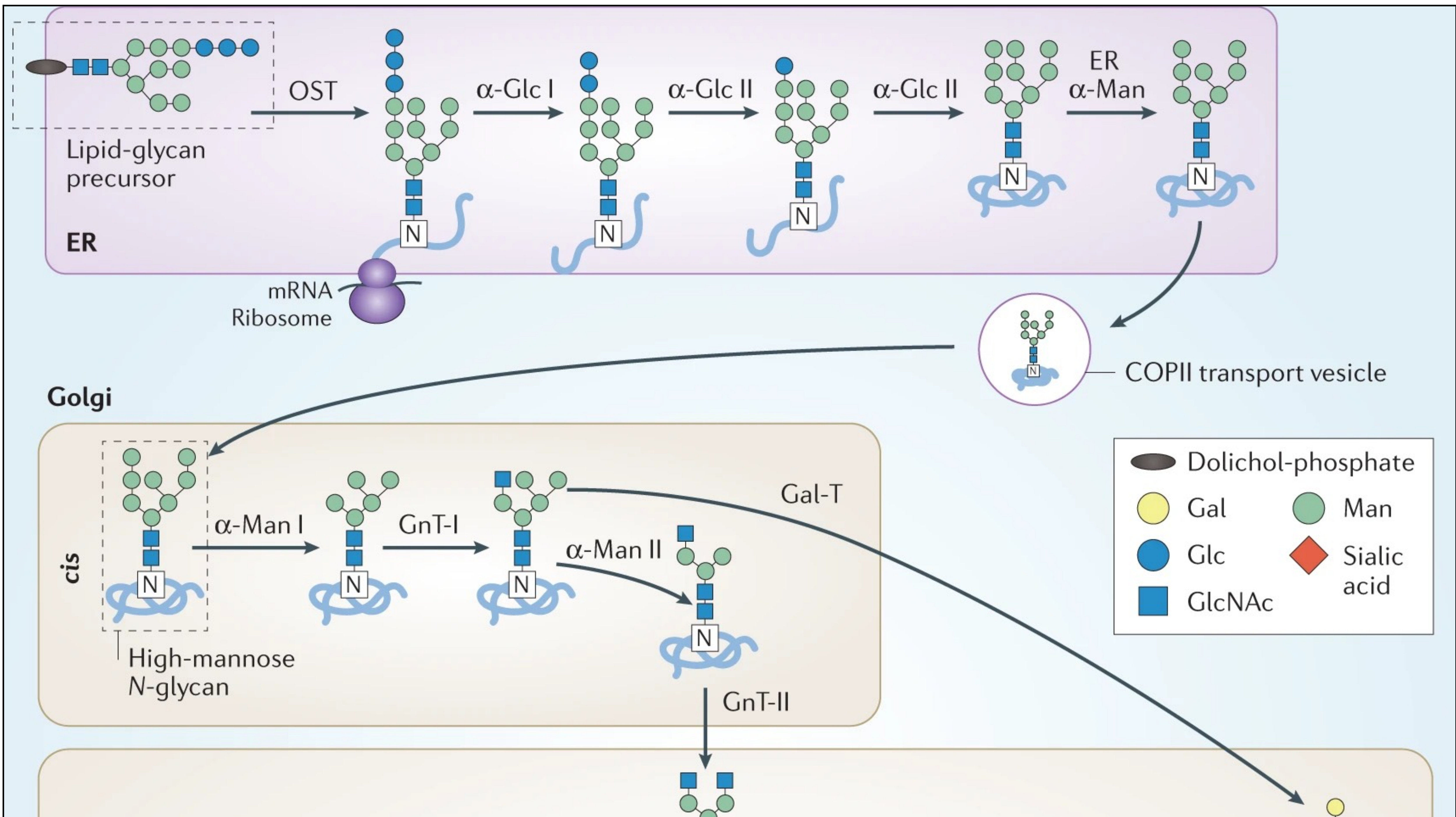

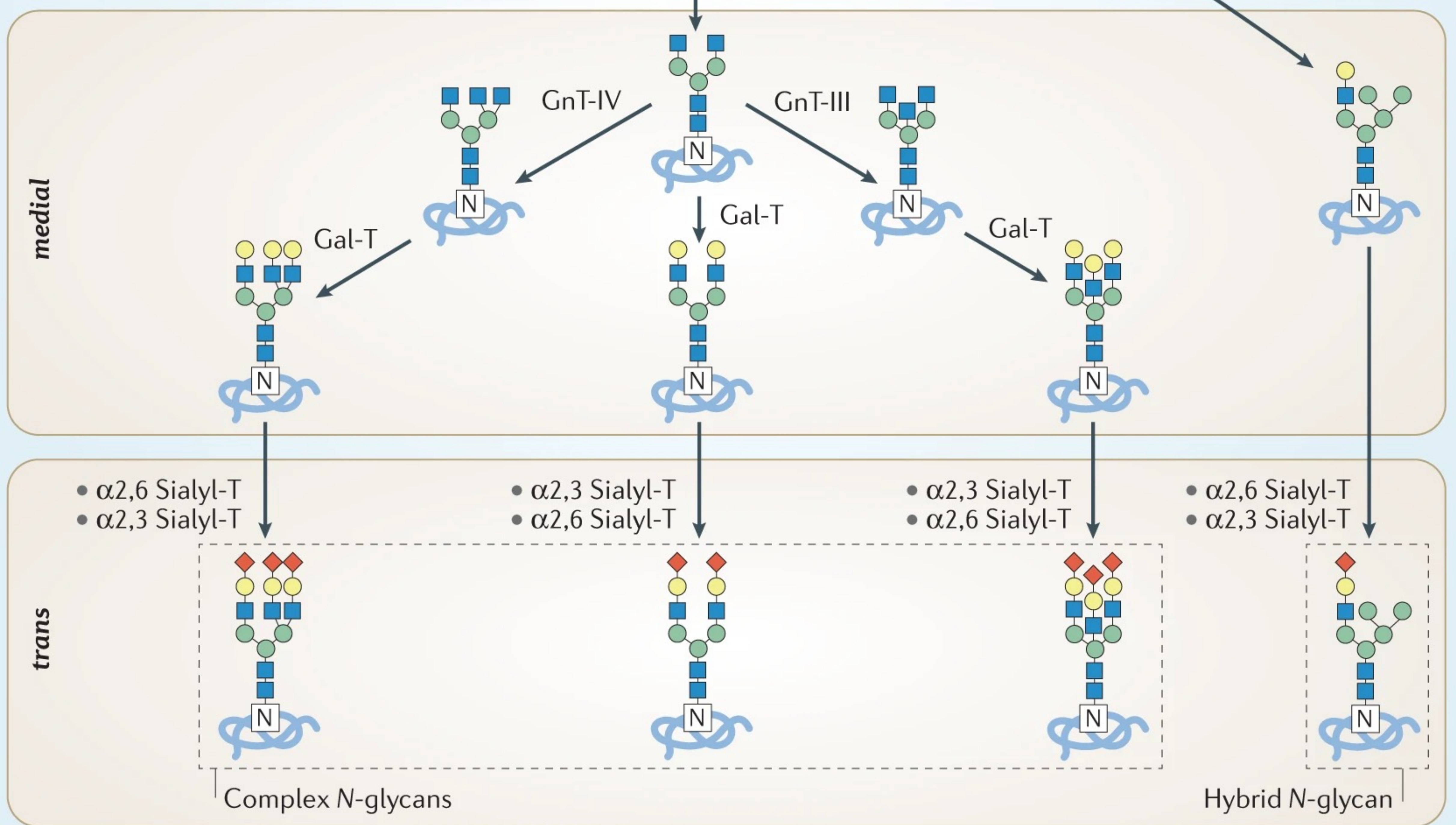

N-glycan diversity

(a)

PDB code 5FJI
High mannose,
GH3 enzyme from
Aspergillus fumigatus

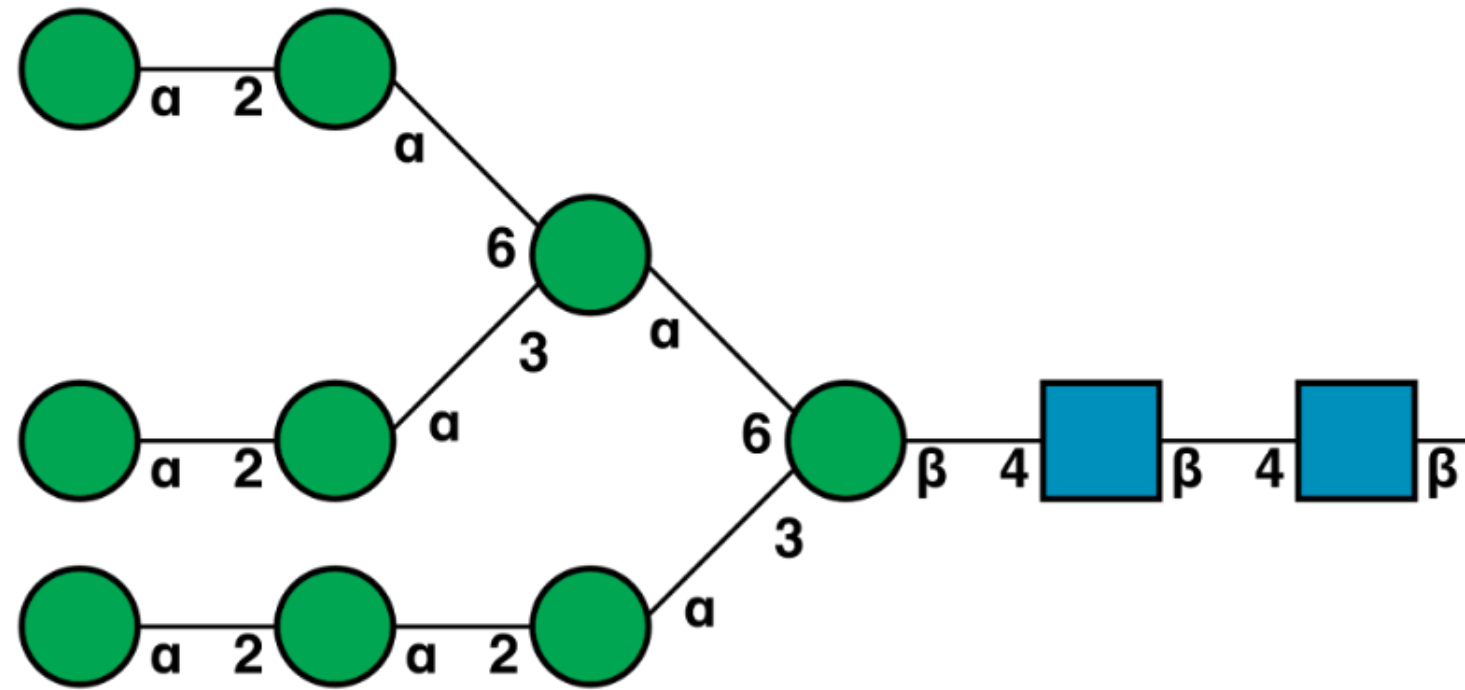

(b)

PDB code 5AOG
Plant glycan,
peroxidase enzyme from
Sorghum bicolor

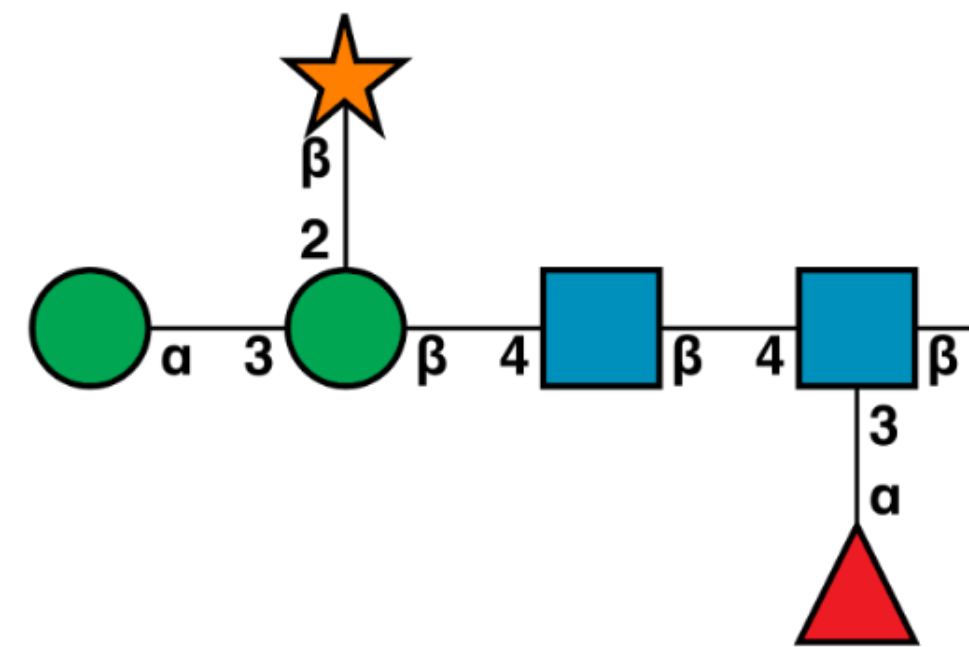

(c)

PDB code 3SGK
Complex glycan,
antibody from *Homo sapiens*,
expressed in *Cricetulus griseus*

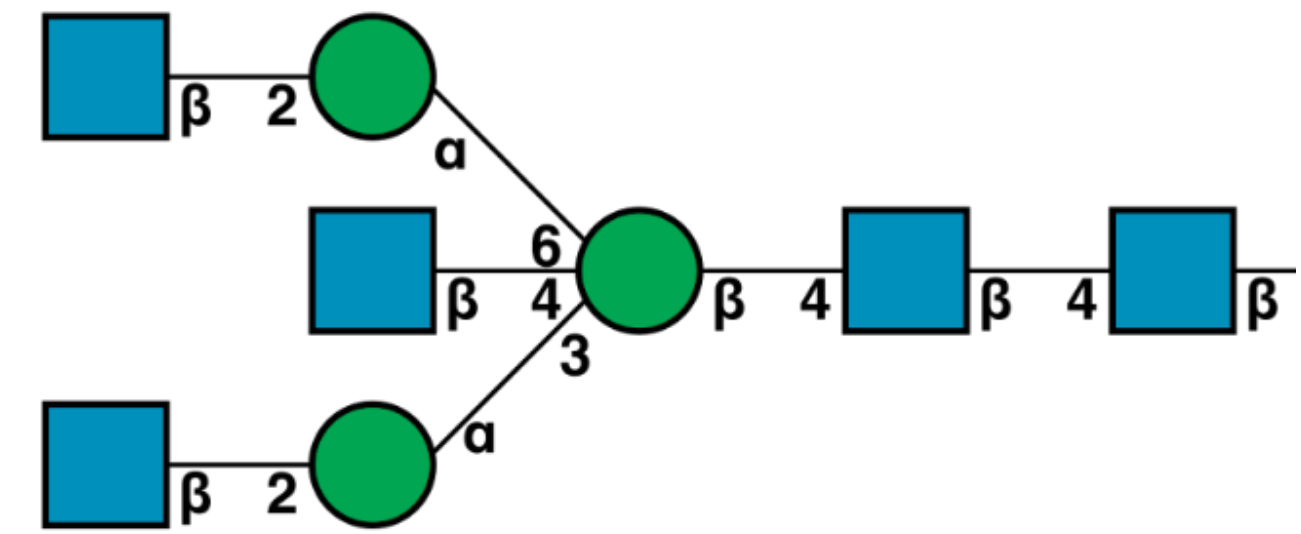

(d)

PDB code 4BYH
Sialylated complex glycan,
antibody from *Homo sapiens*

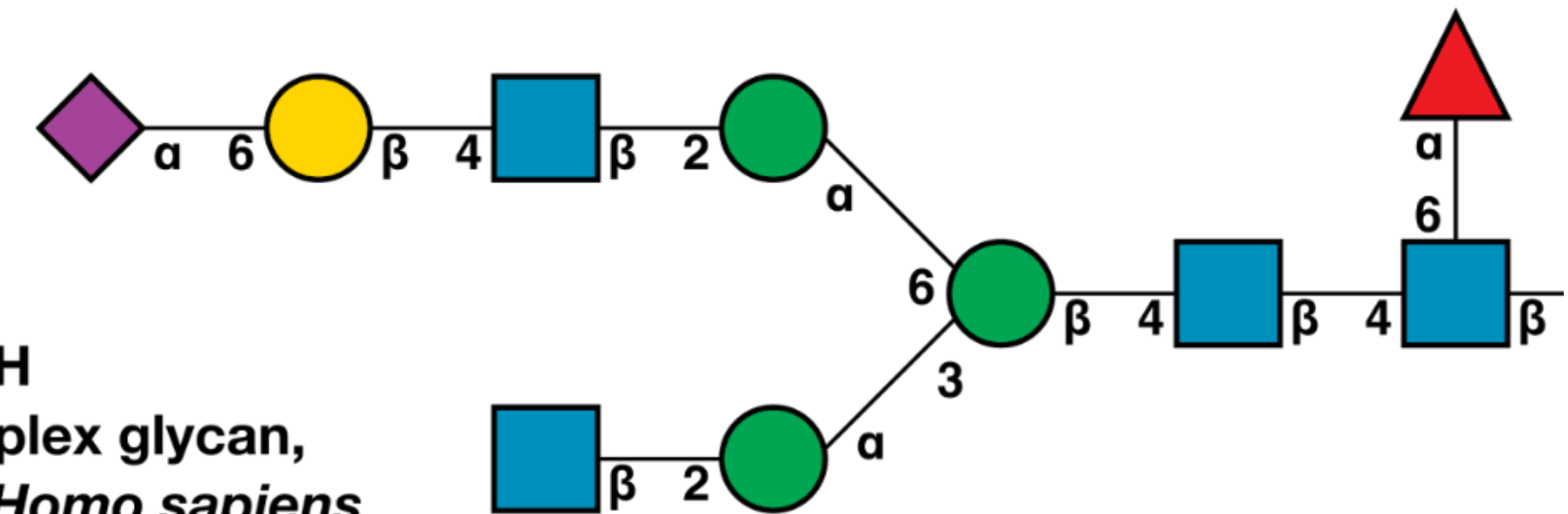

GlcNAc
(NAG, NDG)

Man
(MAN, BMA)

Gal
(GLA, GAL)

Neu5Ac
(SIA, SLB)

Fuc
(FUC, FUL)



Xyl
(XYS, XYP)

Symbol Nomenclature For Glycans (SNFG)

SNFG: Symbol Nomenclature for Graphical Representation of Glycans, Glycobiology 25: 1323-1324, 2015.

Protein glycosylation

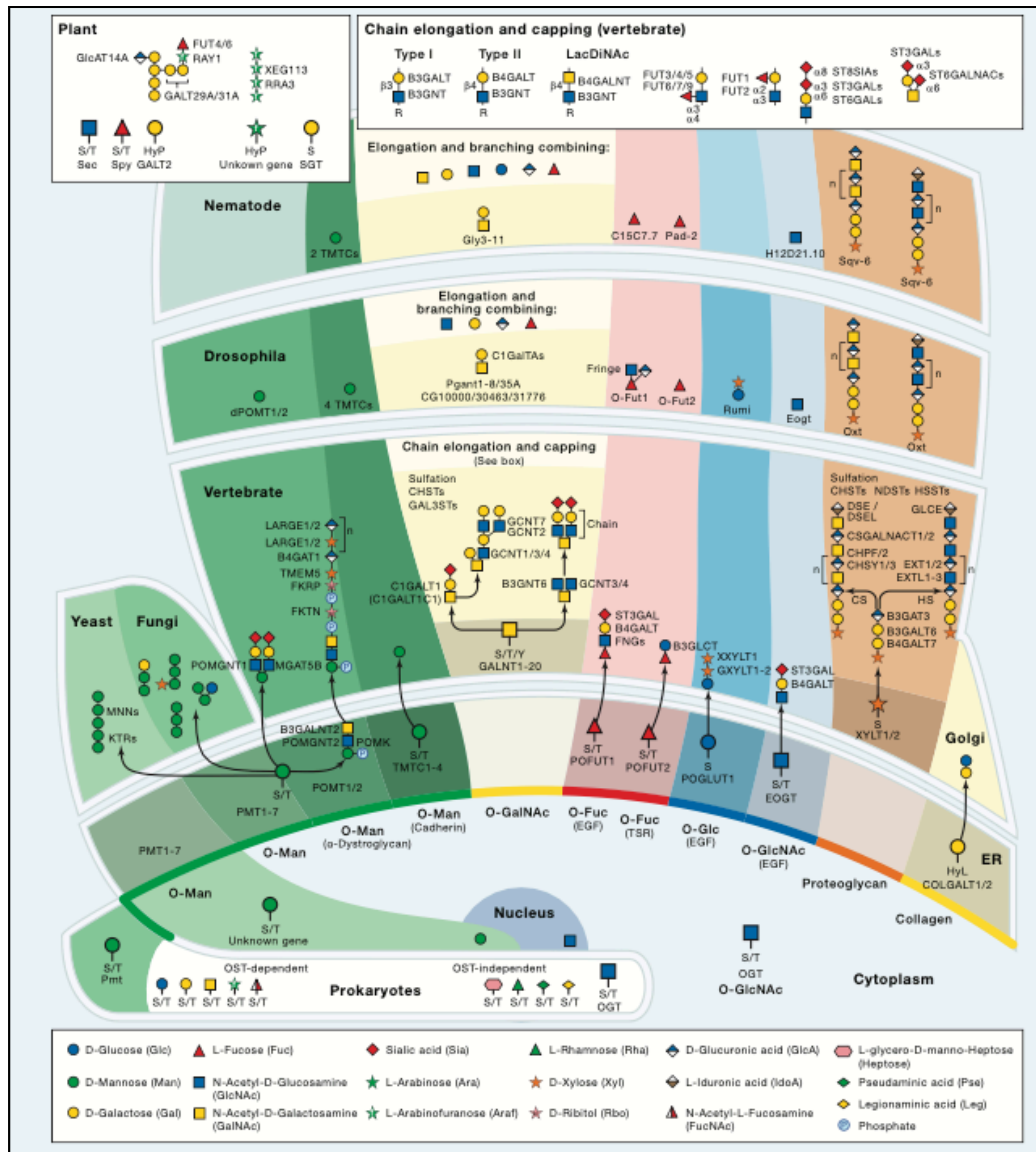
O- and C-glycans



O-GalNAc (o-glycan)



Tryptophan mannosylation (c-glycan)



Joshi, Narimatsu, Schjoldager, Tytgat, Aebi, Clausen & Halim, 2018, Cell 172.

Glycans matter

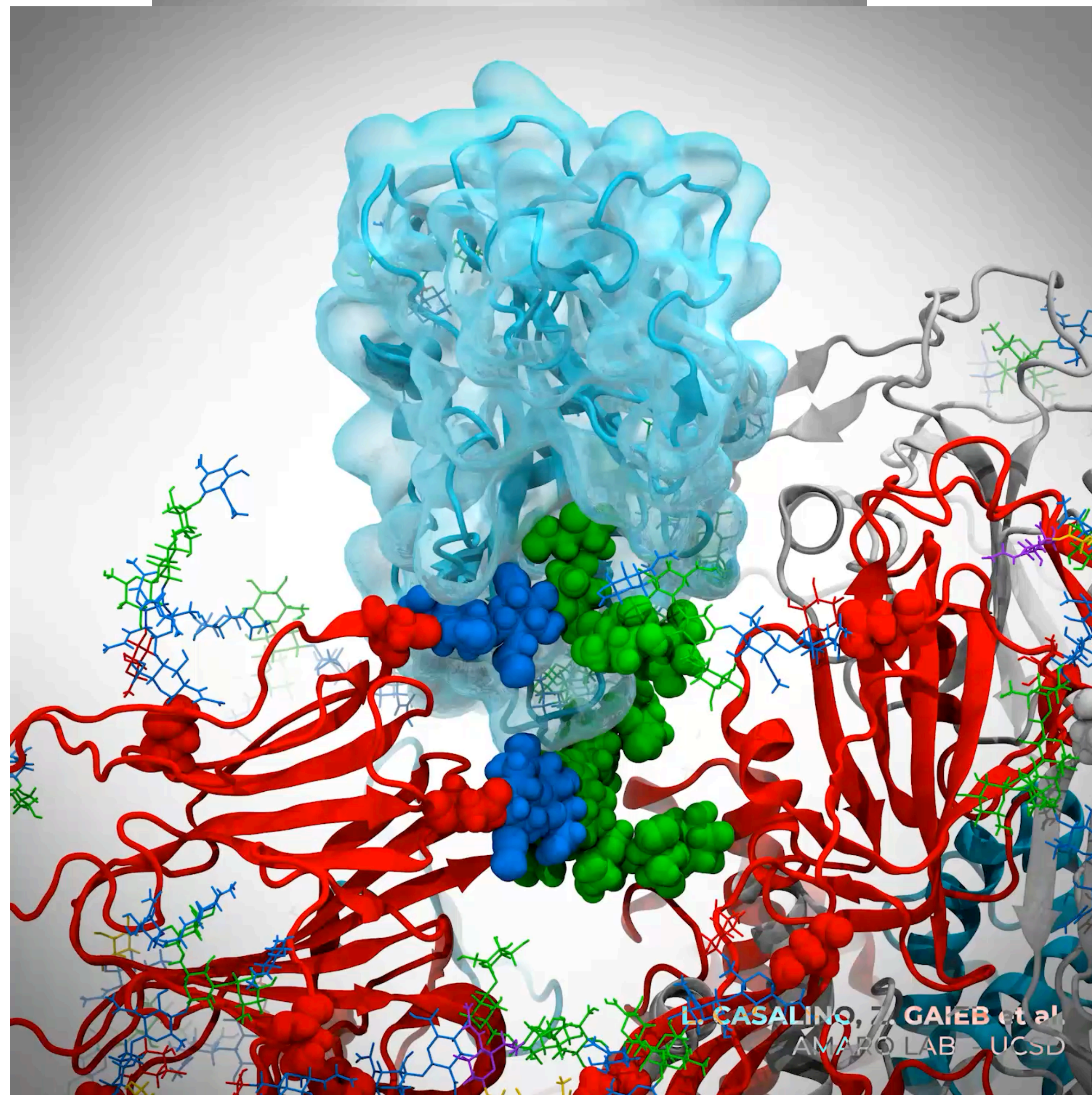

b, Goldsmith,
er, Harbison,
s, Taylor,
da, 2021, ACS
e 6(10):1722-34.

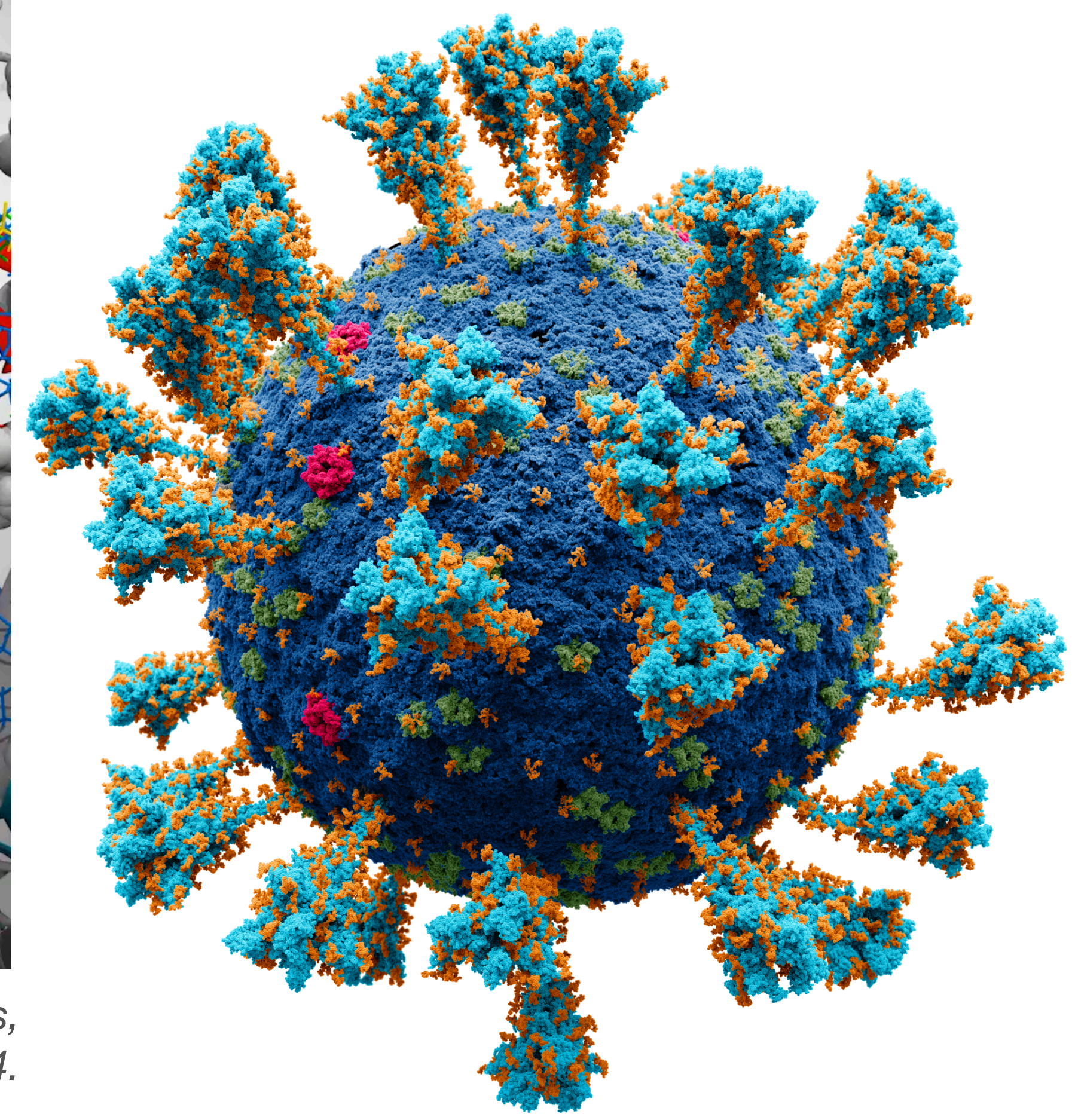

Casalino, Galeb, Goldsmith, Hjorth, Dommer, Harbison, Fogarty, Barros,
Taylor, McLellan, Fadda, 2021, ACS Central Science 6(10):1722-34.

L. CASALINO, Z. GAIEB et al.
AMARO LAB - UCSD

Mechanistic studies show
how things may work

**But simulations will only make sense
if the atomic models used are correct**

**Are all atomic
models correct?**

Carbohydrates in the PDB

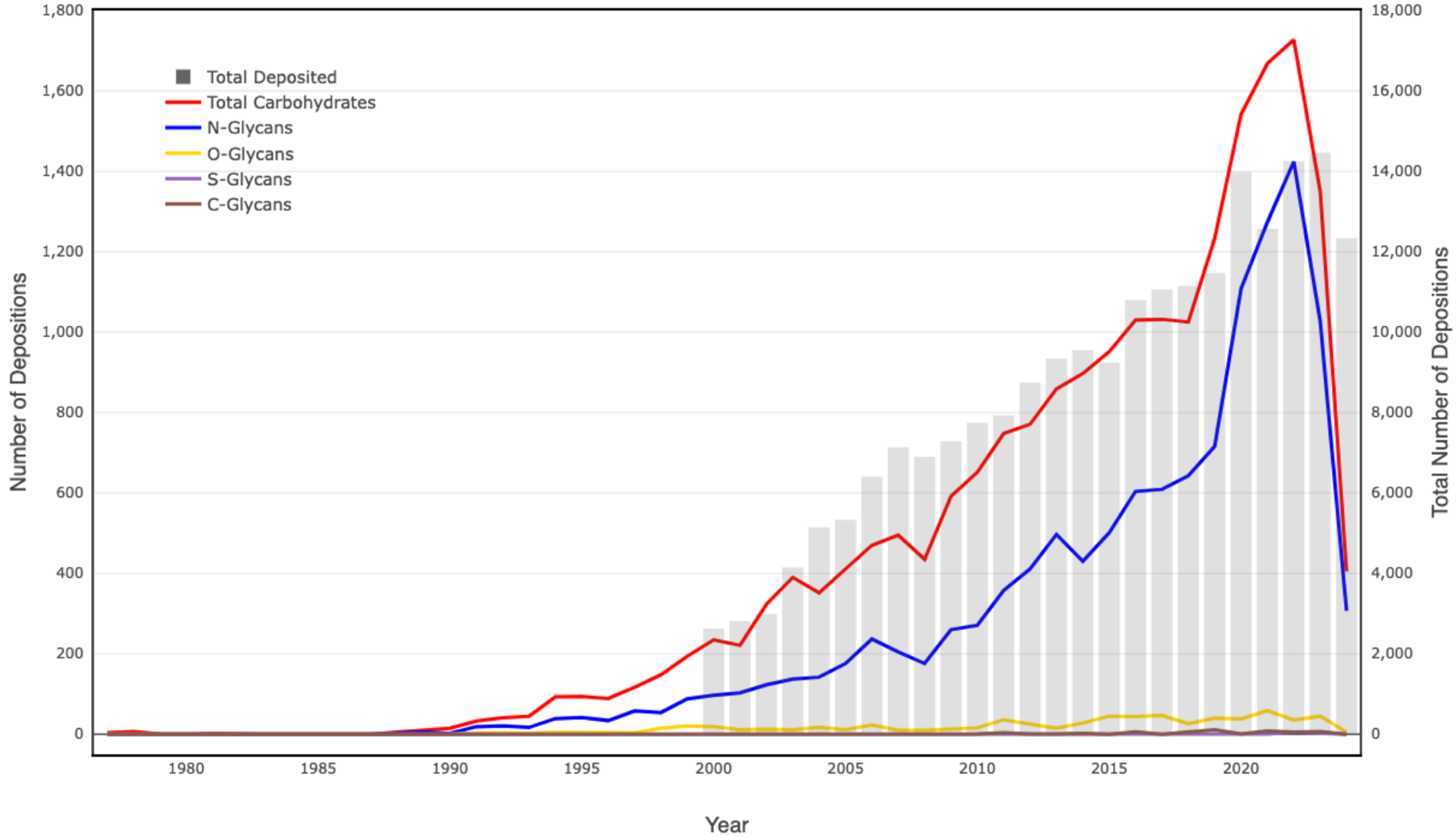

X-ray Crystallography

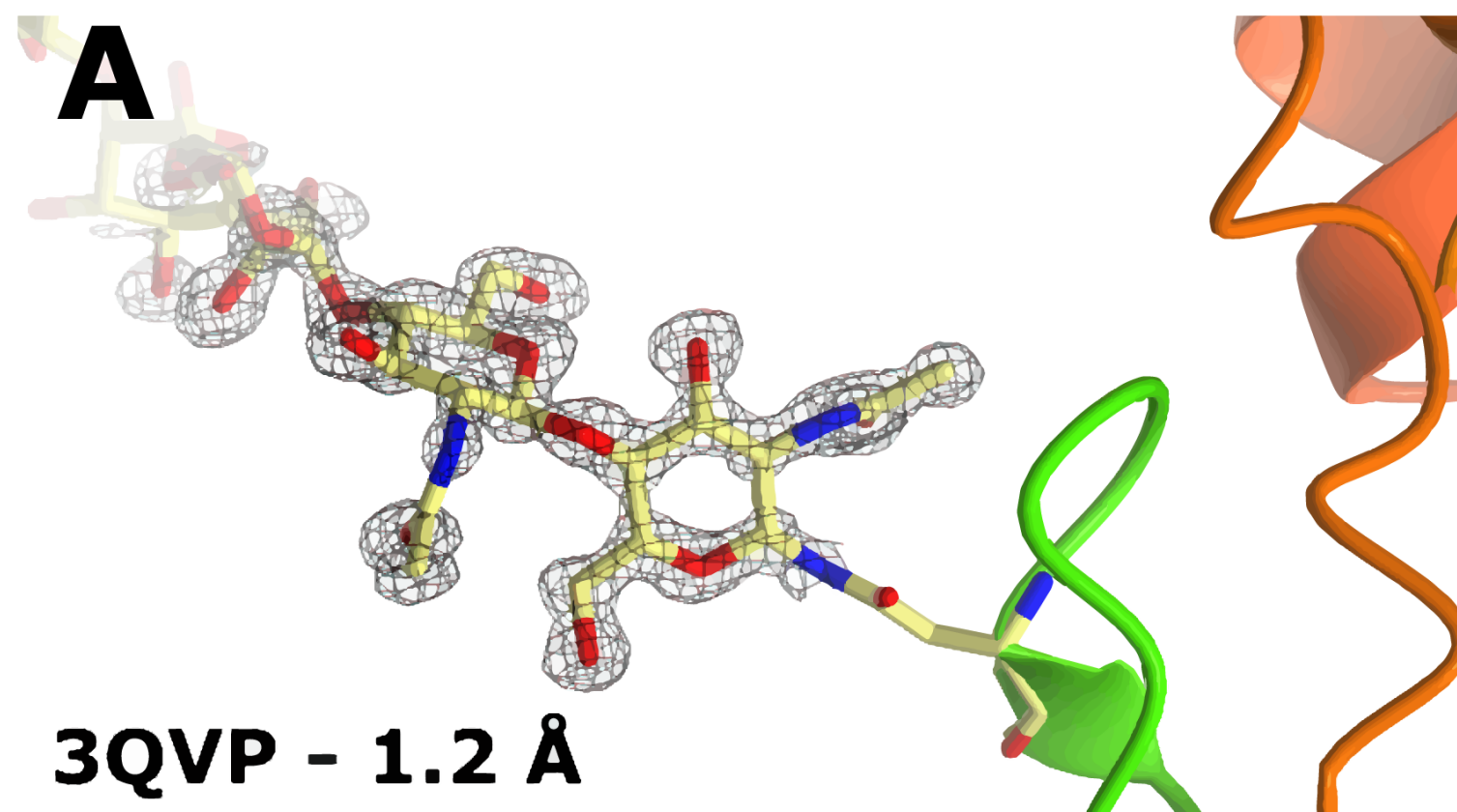
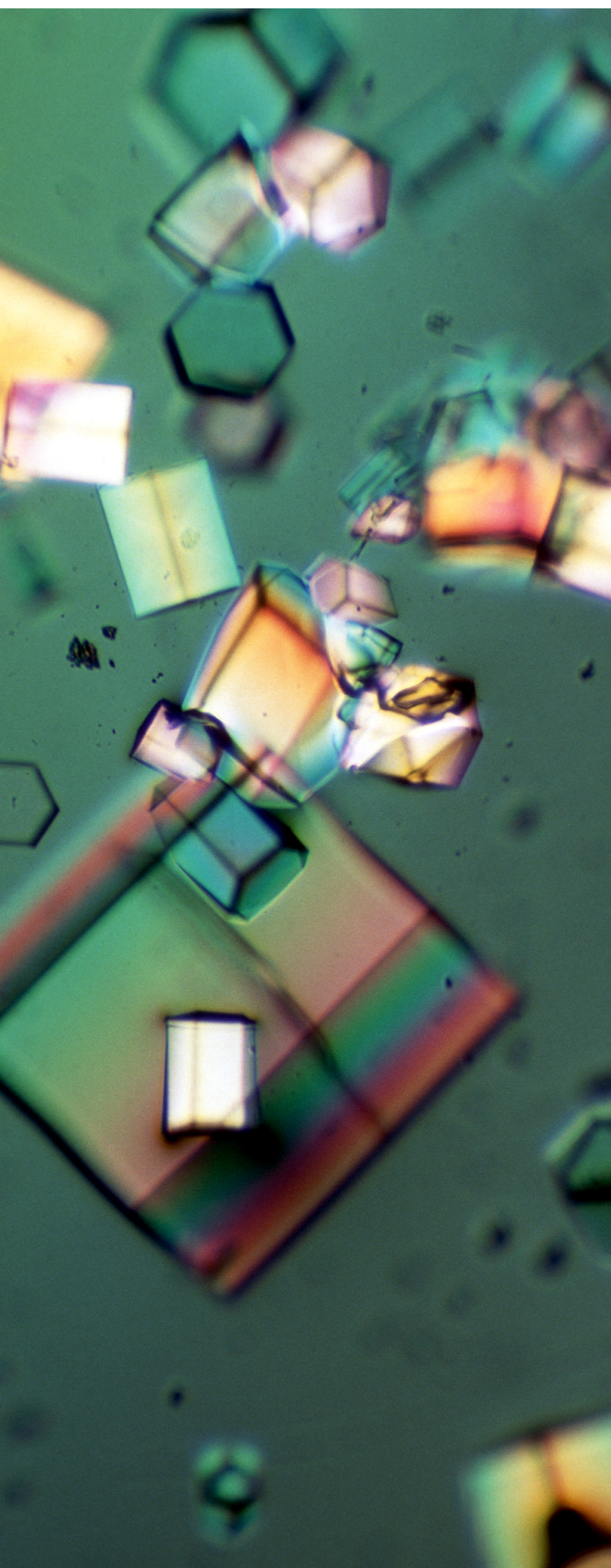

3QVP - 1.2 Å

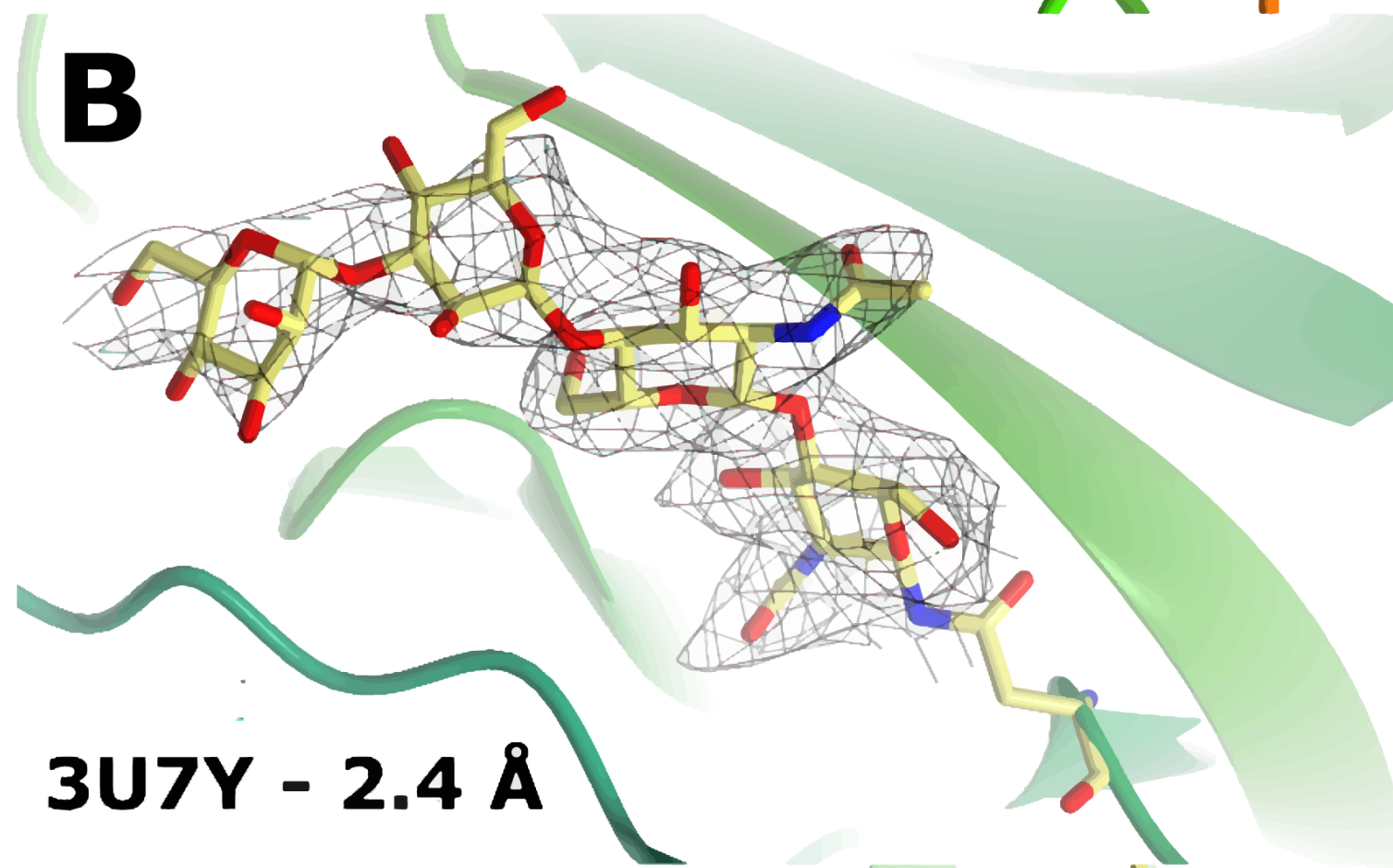

3U7Y - 2.4 Å

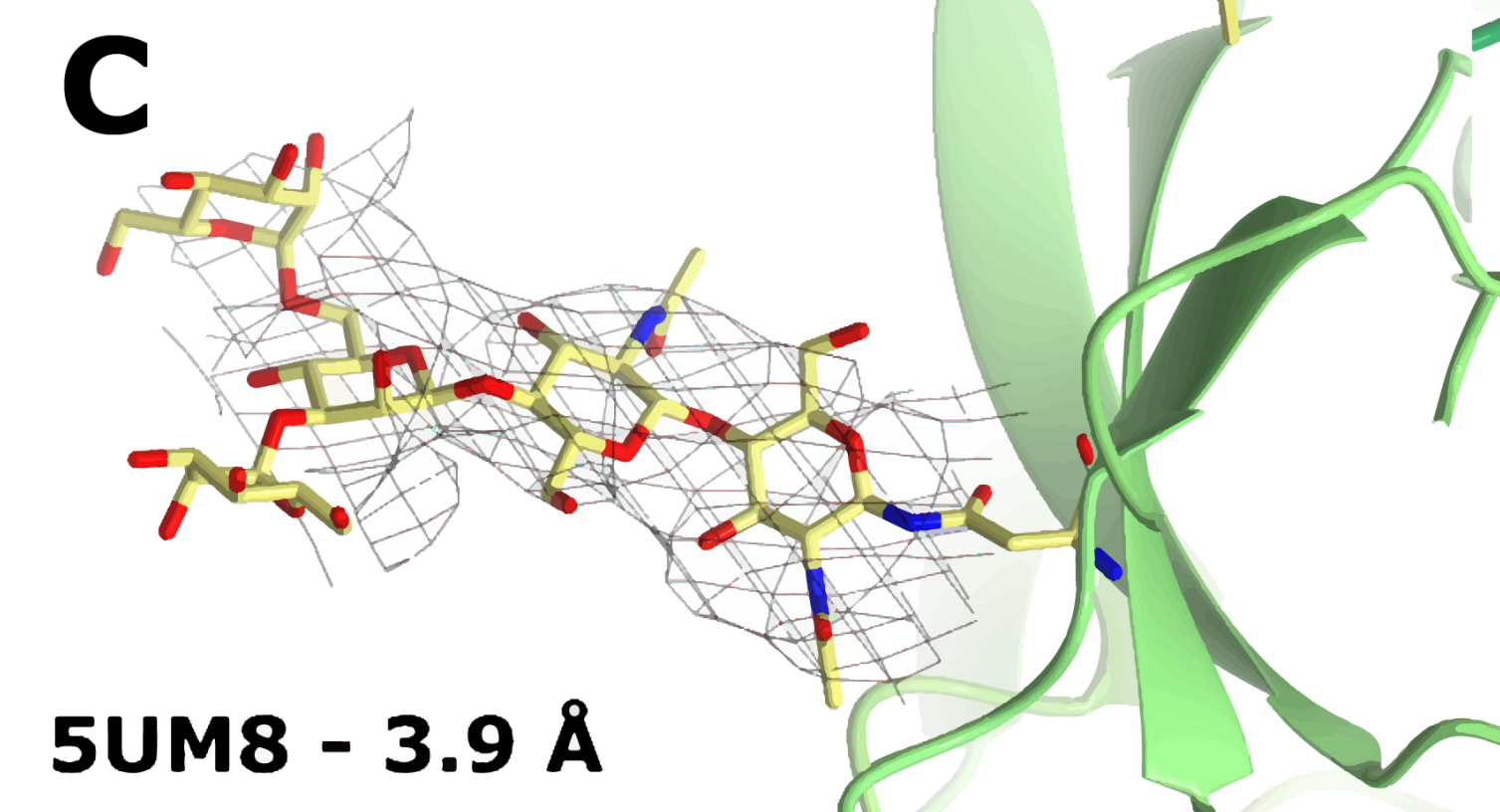

5UM8 - 3.9 Å

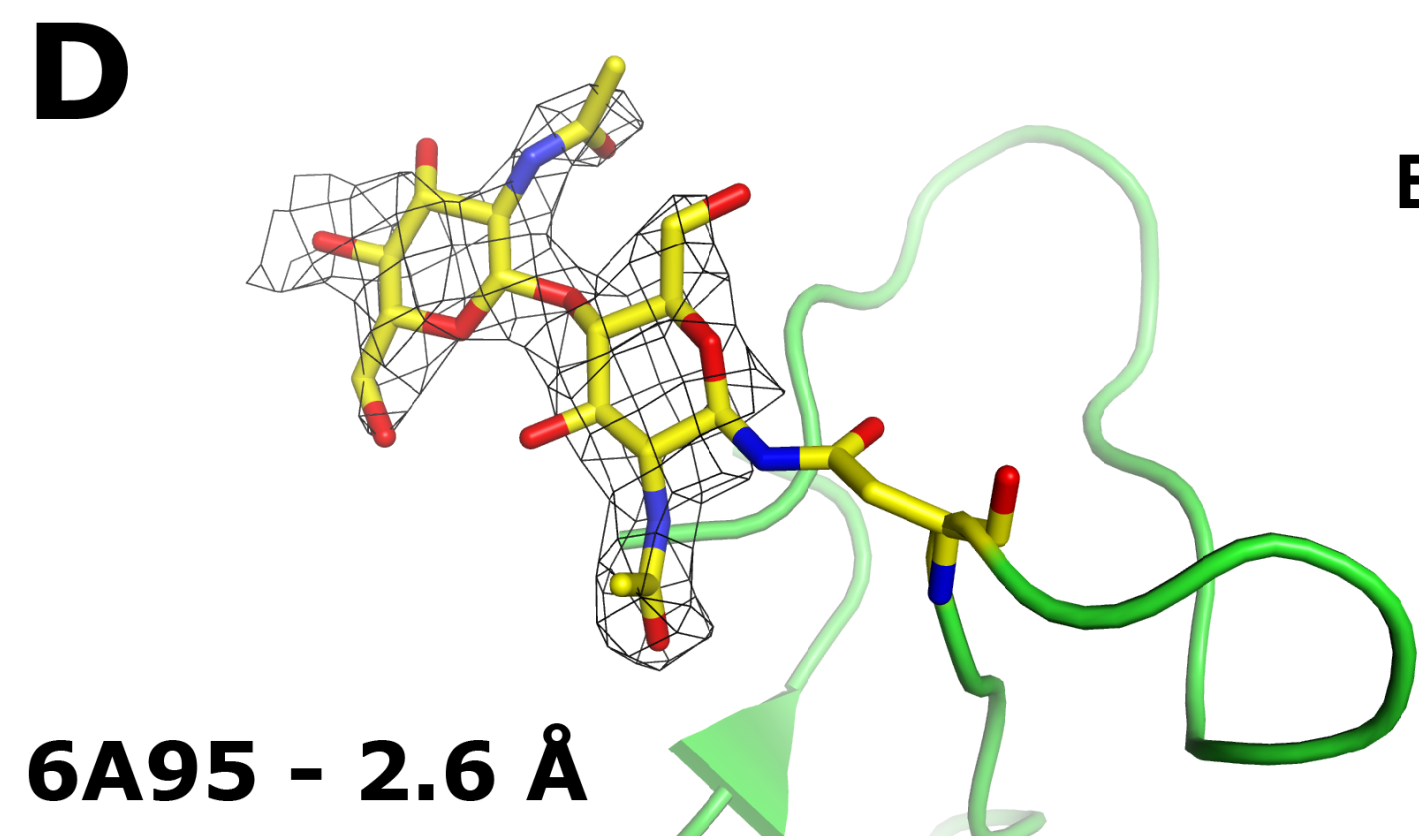

6A95 - 2.6 Å

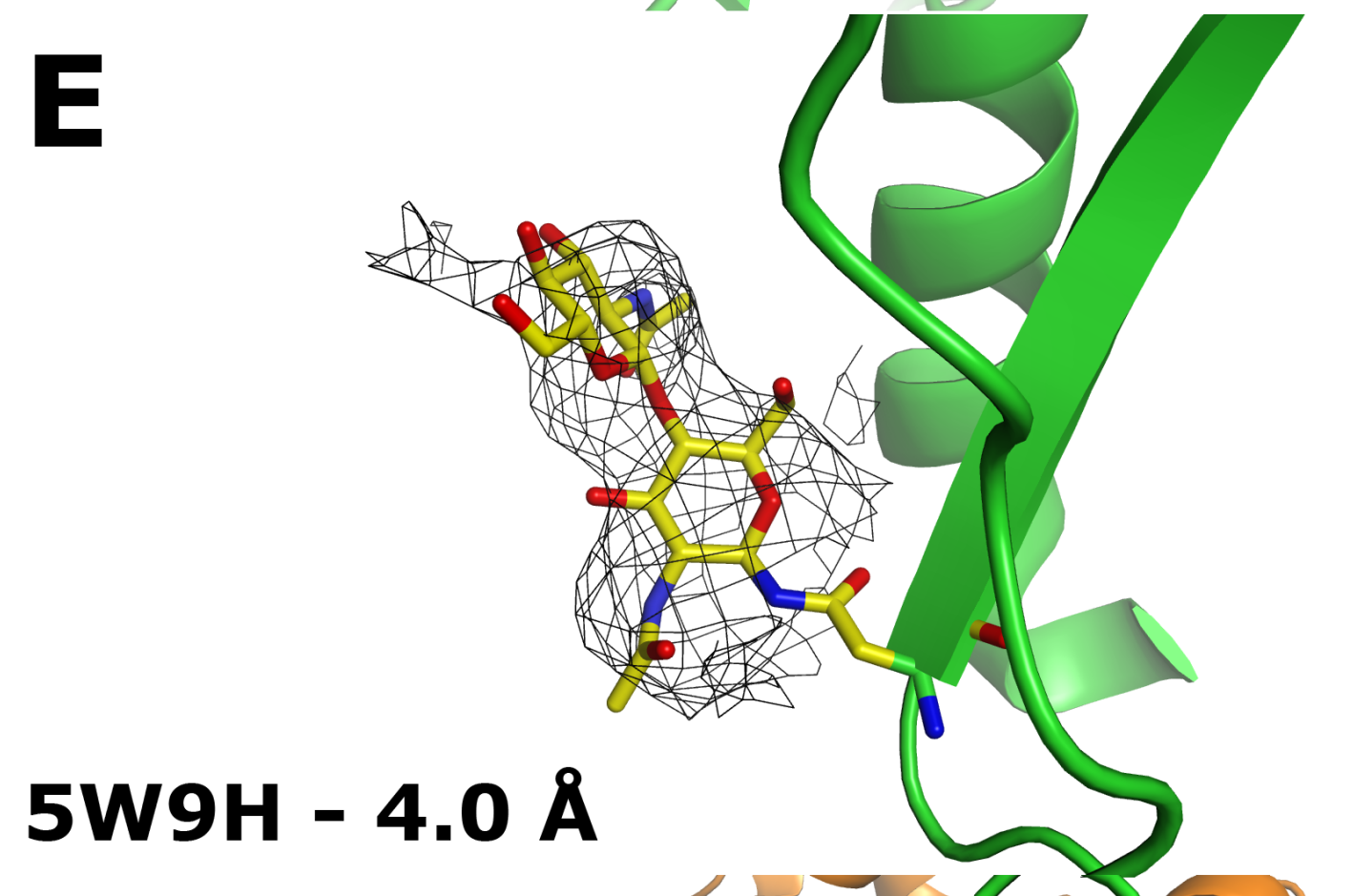

5W9H - 4.0 Å

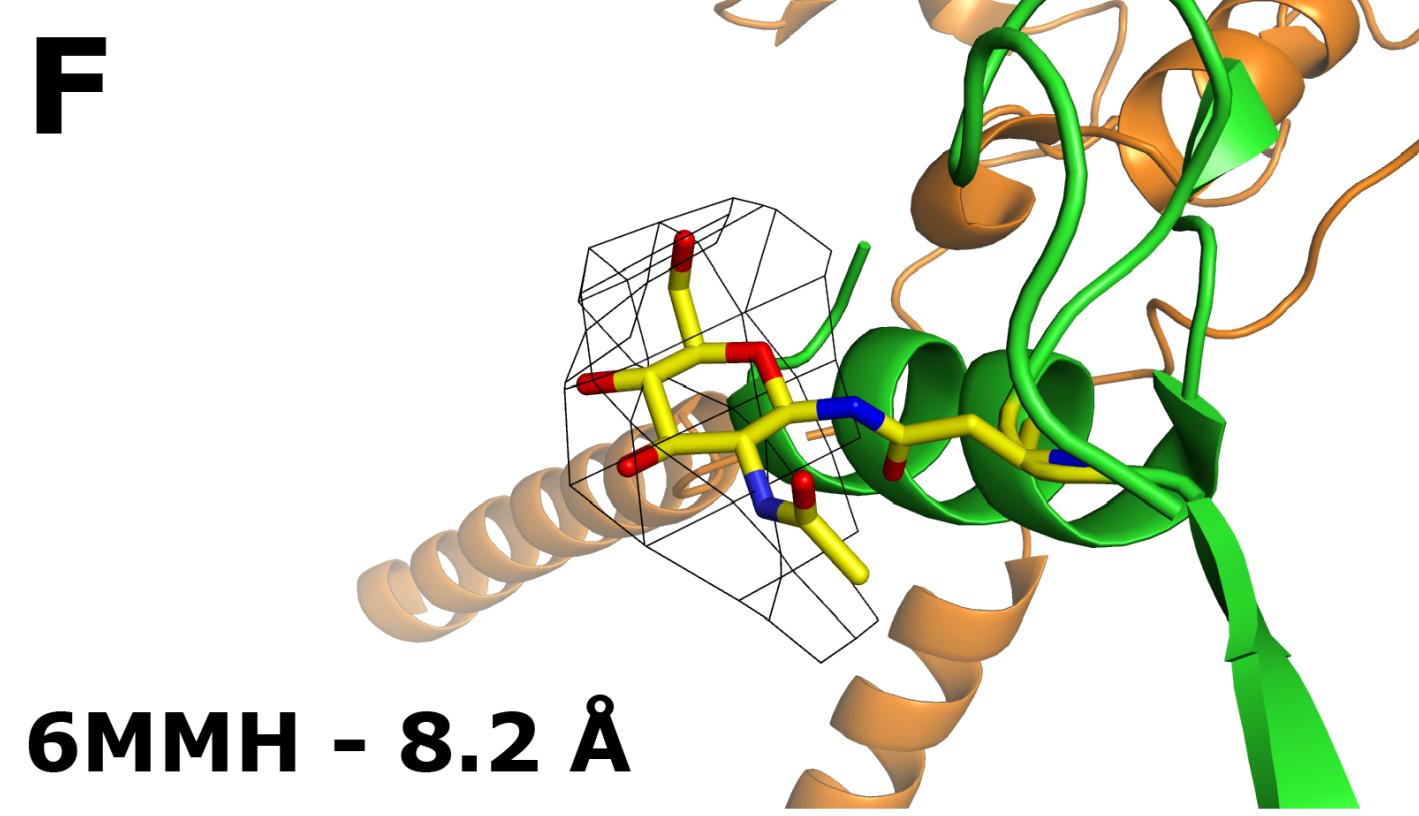

6MMH - 8.2 Å

Electron Cryo-Microscopy

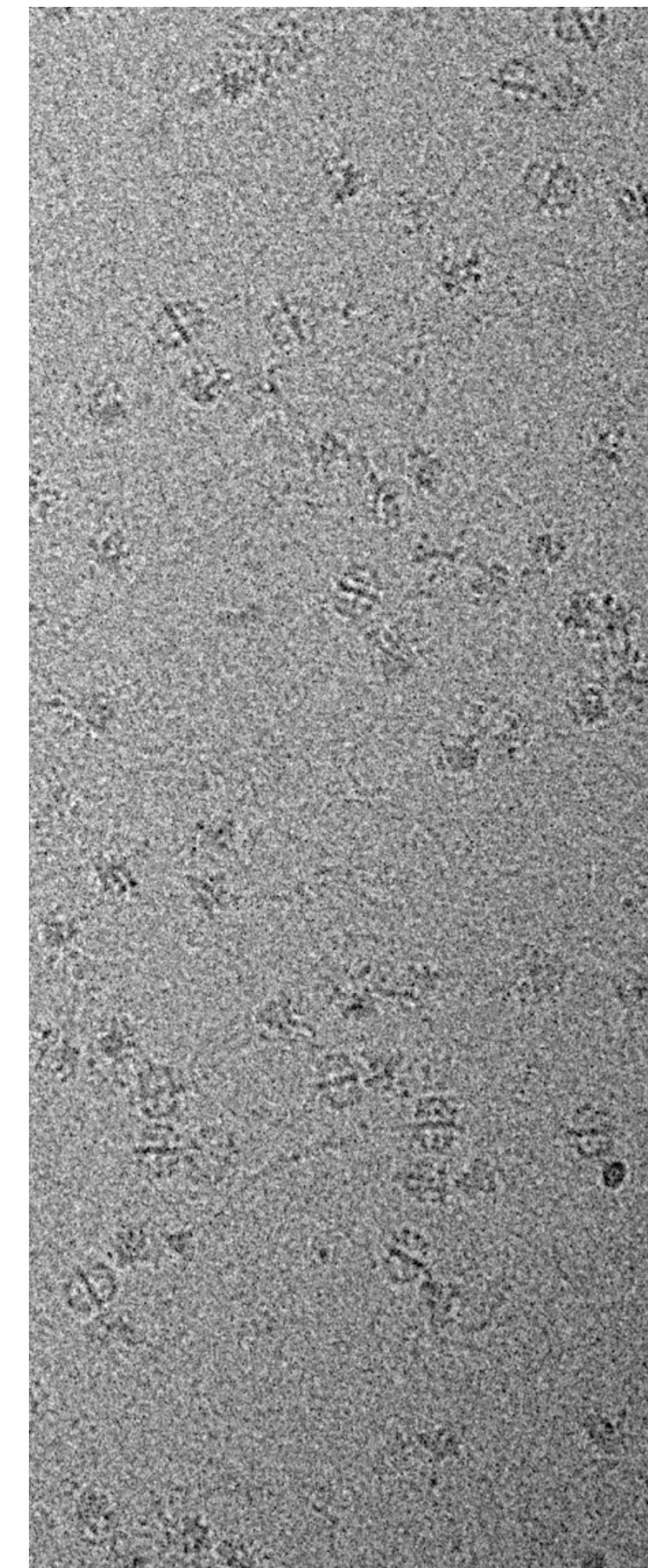

5 forms = 5 codes 🙄🙄

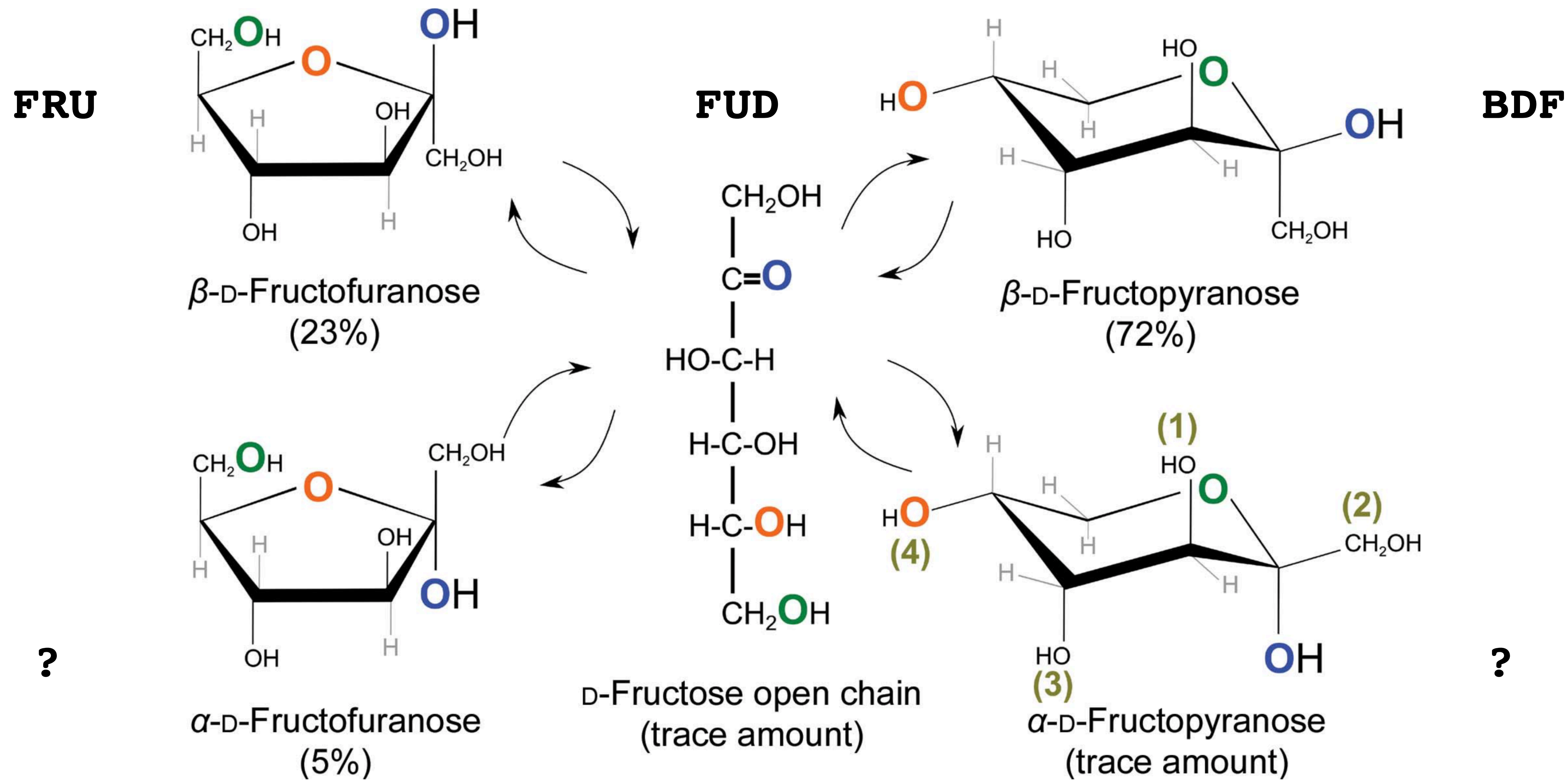

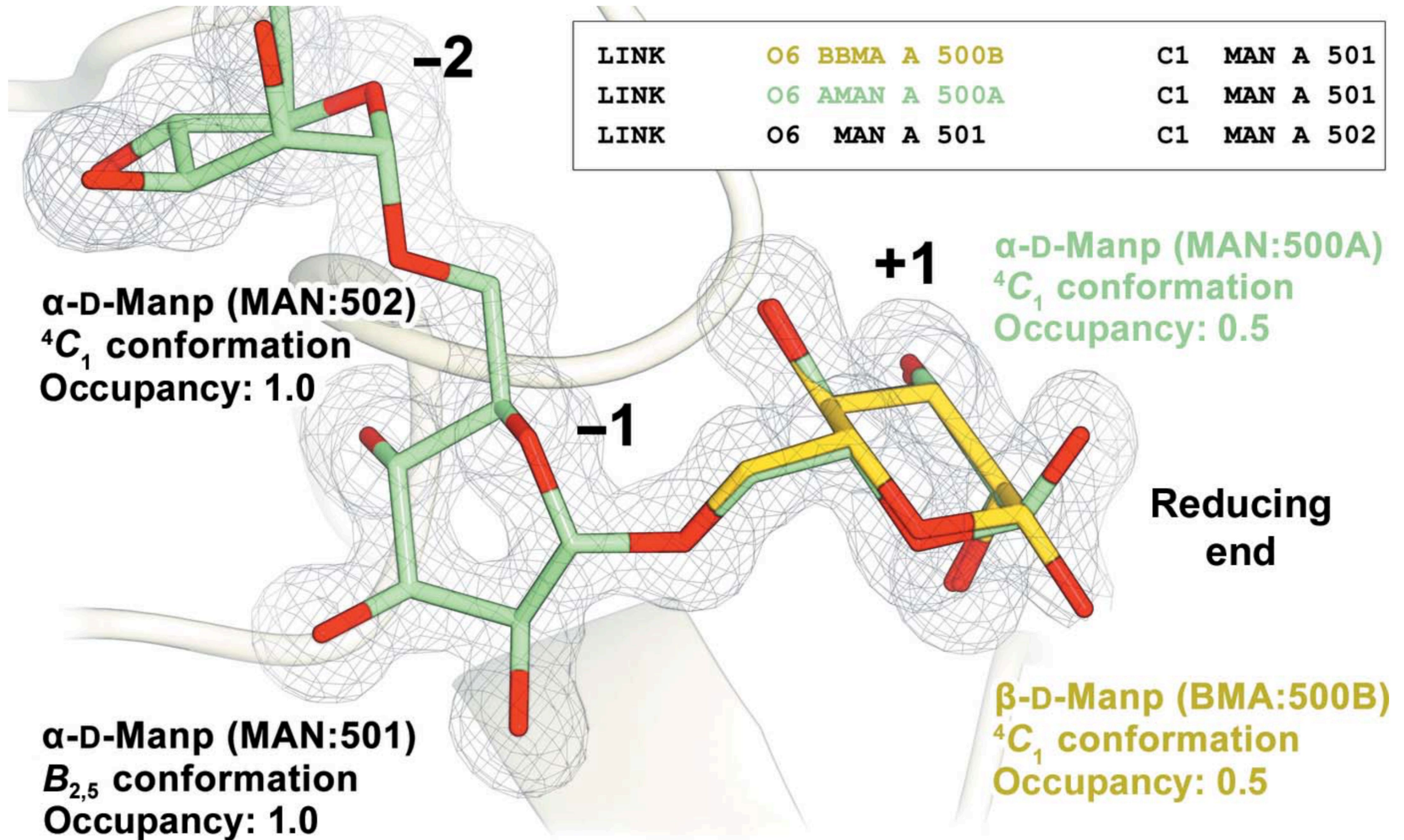

Adapted from Agirre, 2017, Acta Cryst D73(2):171-186

Ring conformation

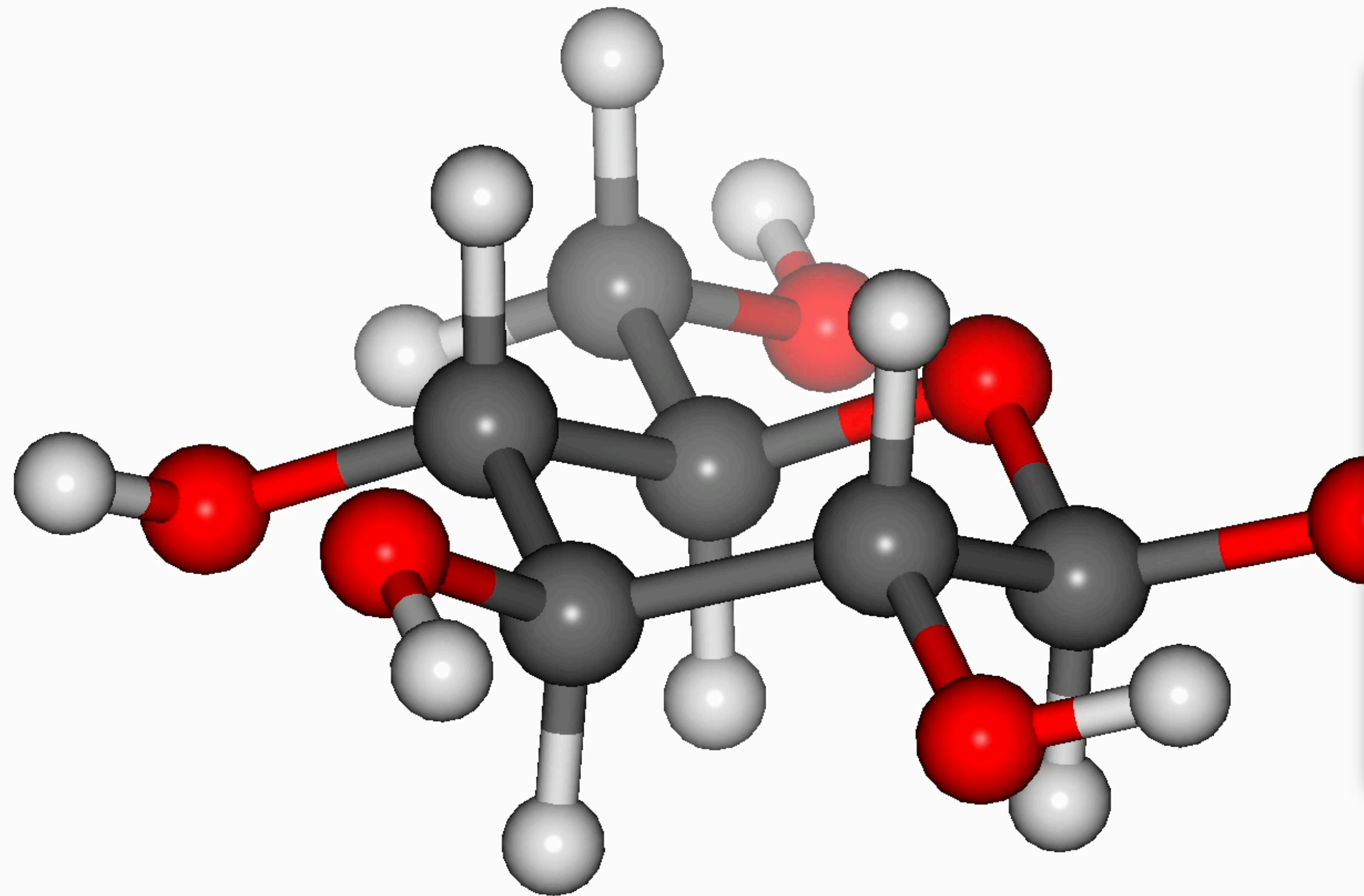

a 4C_1 chair

chairs are comfortable for sugars

Ring conformation

wavy lines indicate which atoms are roughly coplanar

Furanose forms
 - 5-membered rings
 - 2 ring puckers
 - 20 conformations

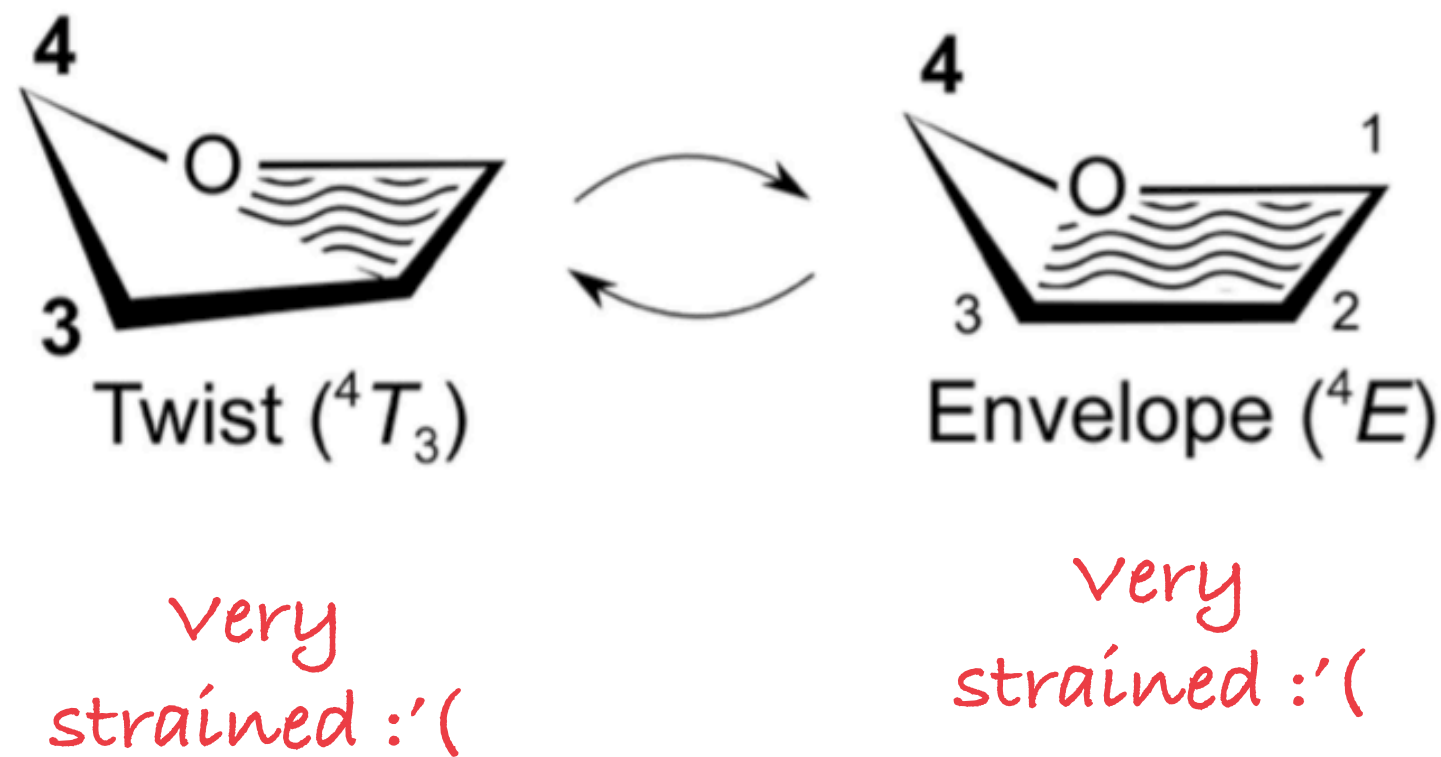
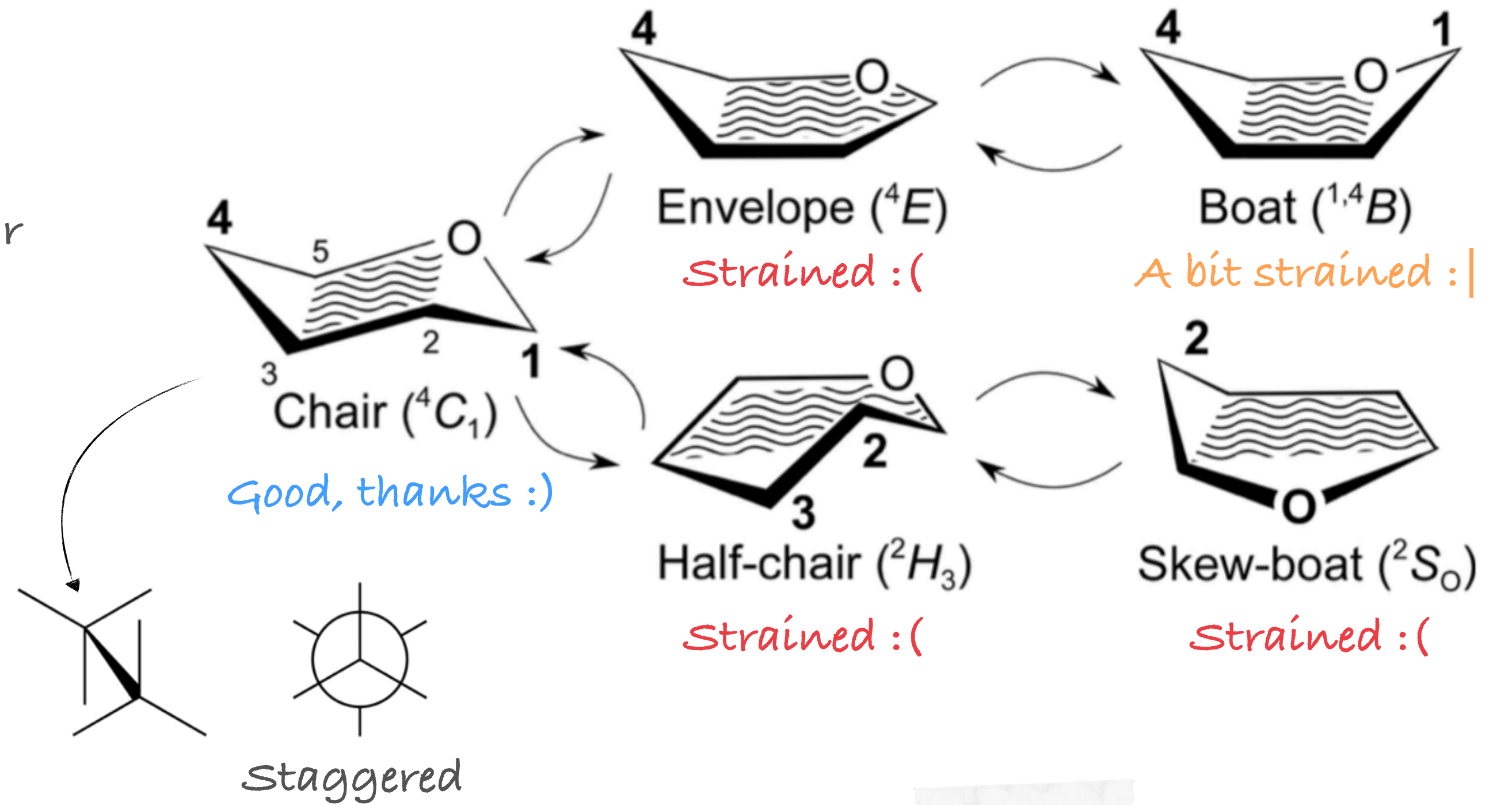

Pyranose forms
 - 6-membered rings
 - 5 ring puckers
 - 38 conformations

Ring conformation

The Cremer-Pople algorithm

Θ and Φ tell us which atoms move away from the mean ring plane, describing the conformation

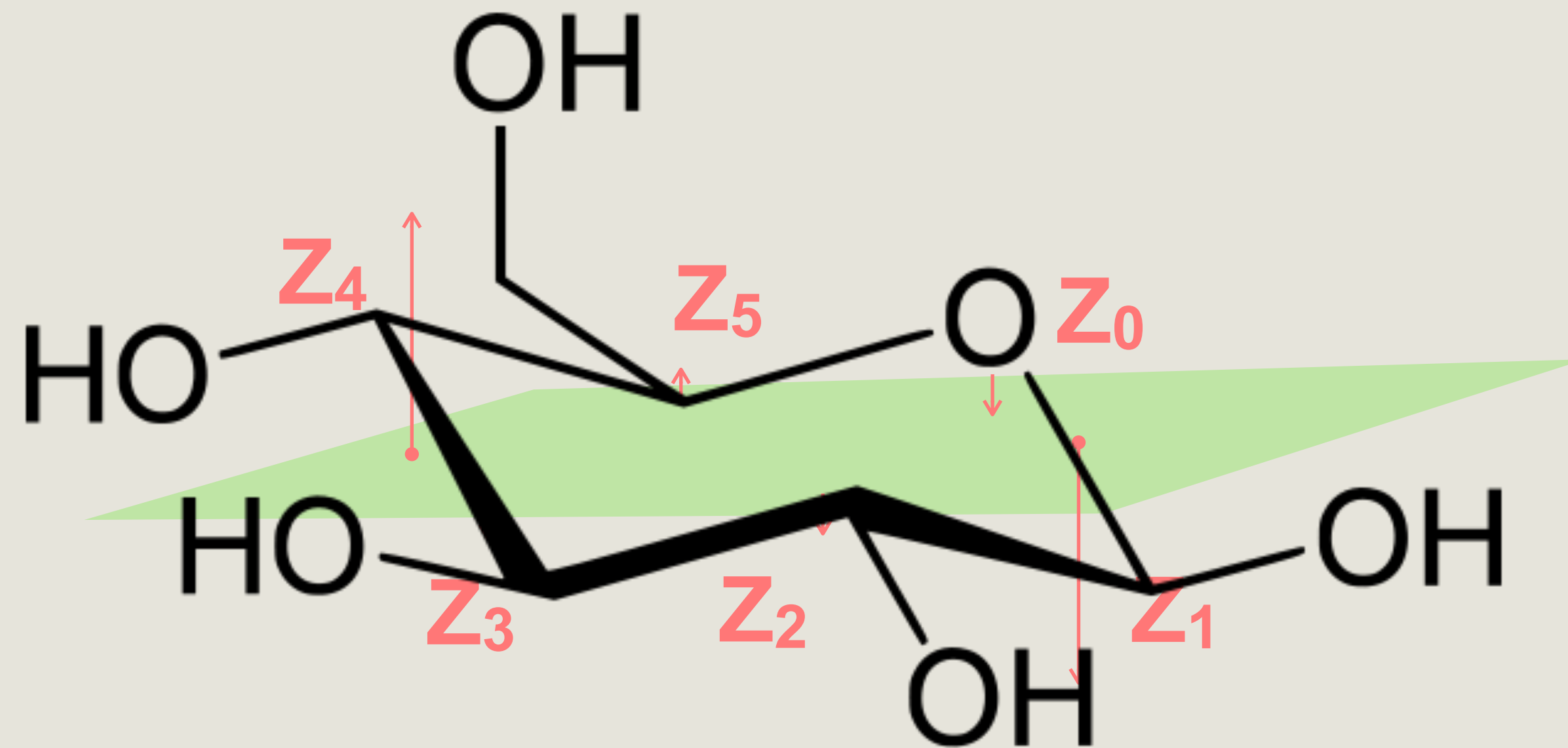

Q tells us by how much:

$$Q = \sqrt{\sum_{i=0}^5 Z_i^2}$$

“total puckering amplitude”

$Q = 0.54 \text{ \AA}$ for an ideal Glucose 4C_1 chair

Cremer & Pople, 1975, JACS 97(6)

Ring conformation

The Cremer-Pople algorithm

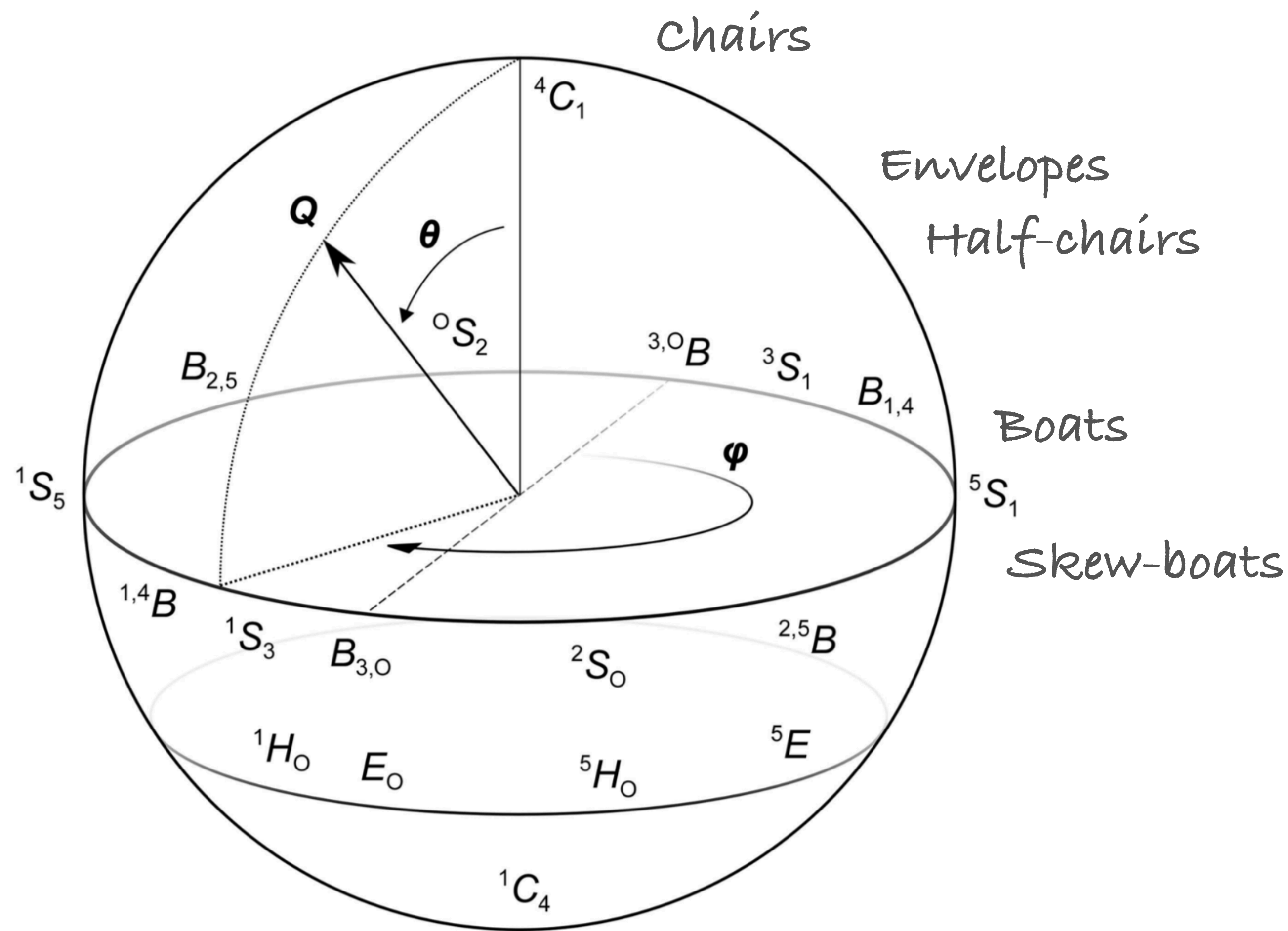
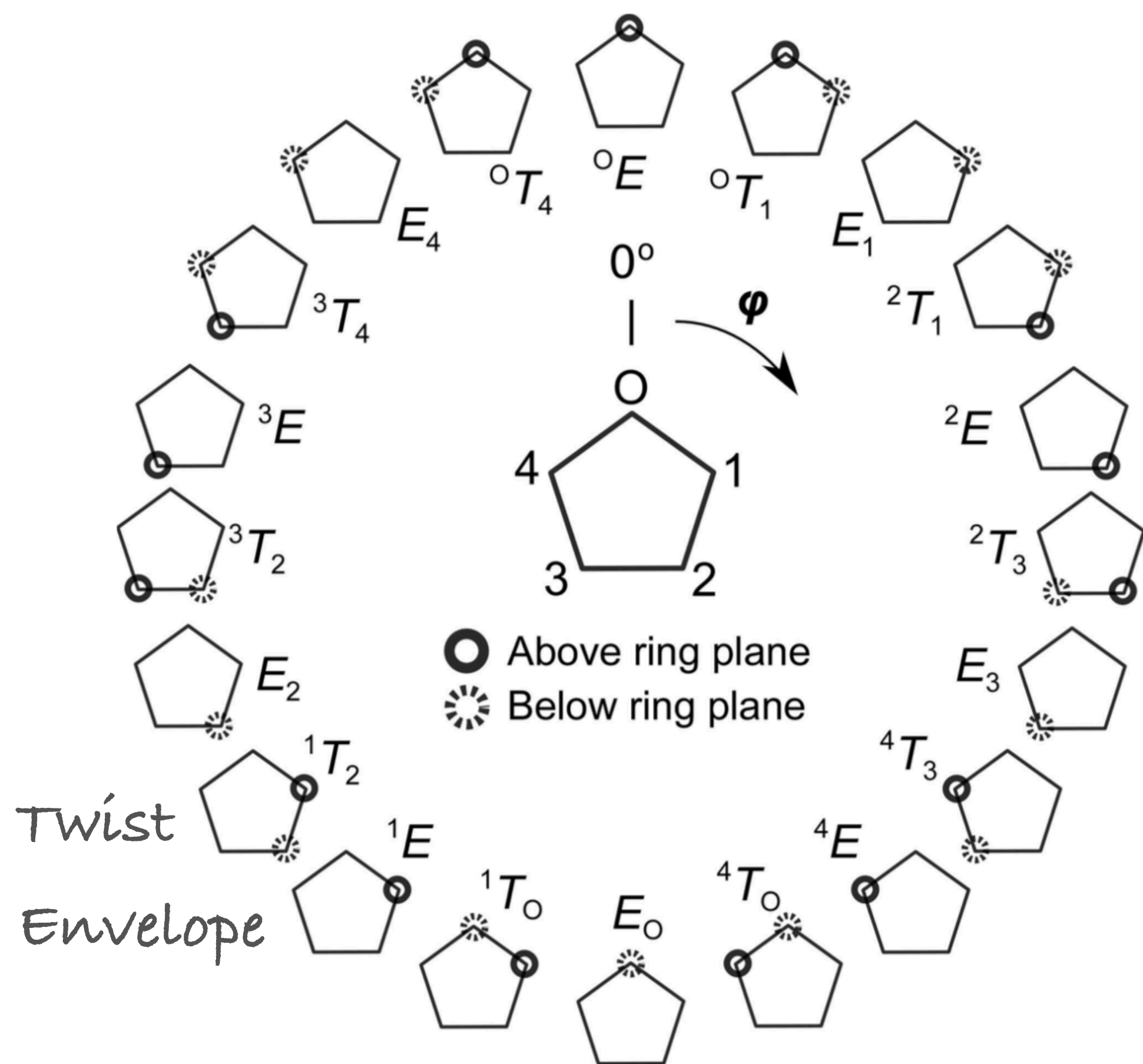

Ring conformation

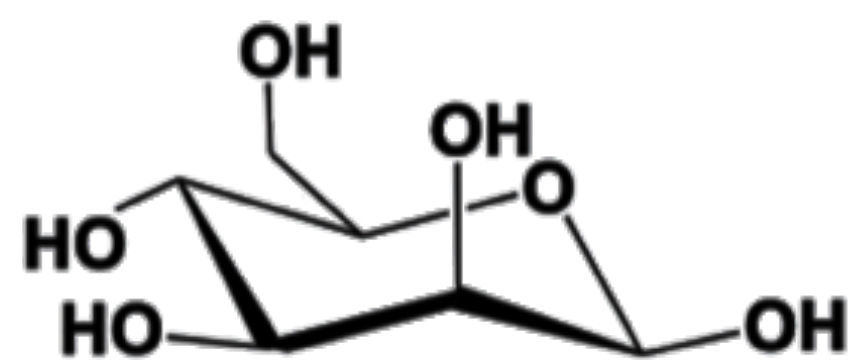
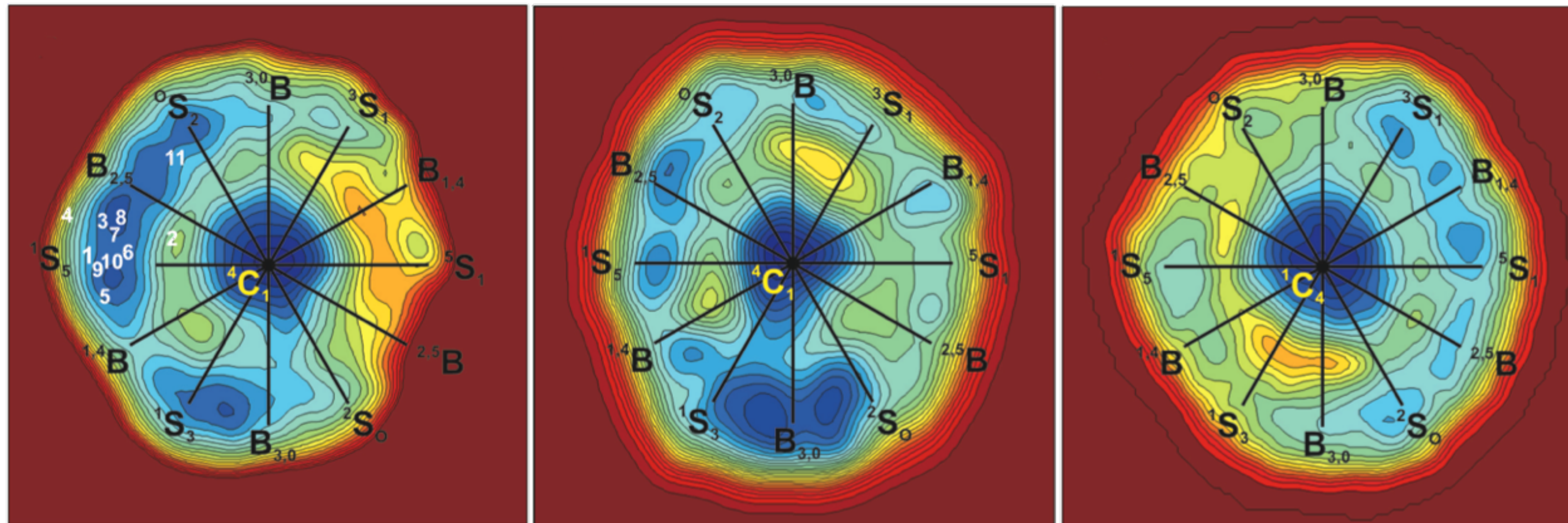
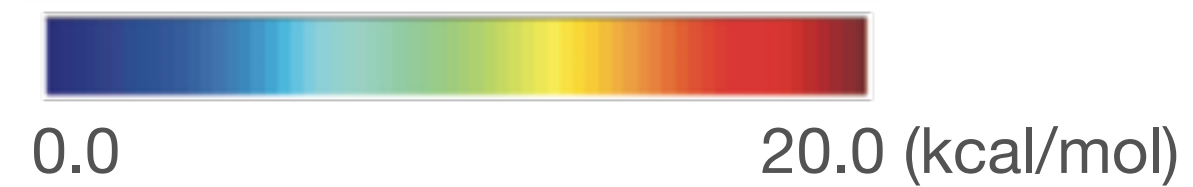

β -D-Mannopyranose

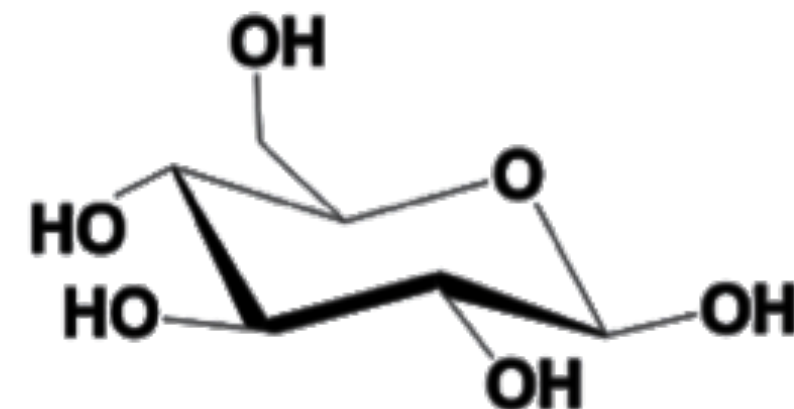

β -D-Glucopyranose

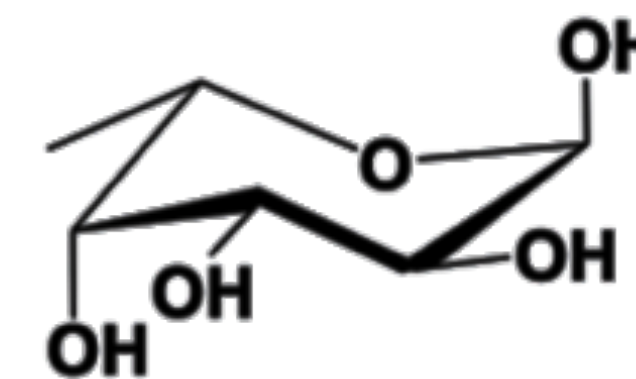

α -L-Fucopyranose

Ring conformation in protein glycosylation

- Many more **high-energy** conformations than expected.
- Clear need for **carbohydrate specific methodology**.

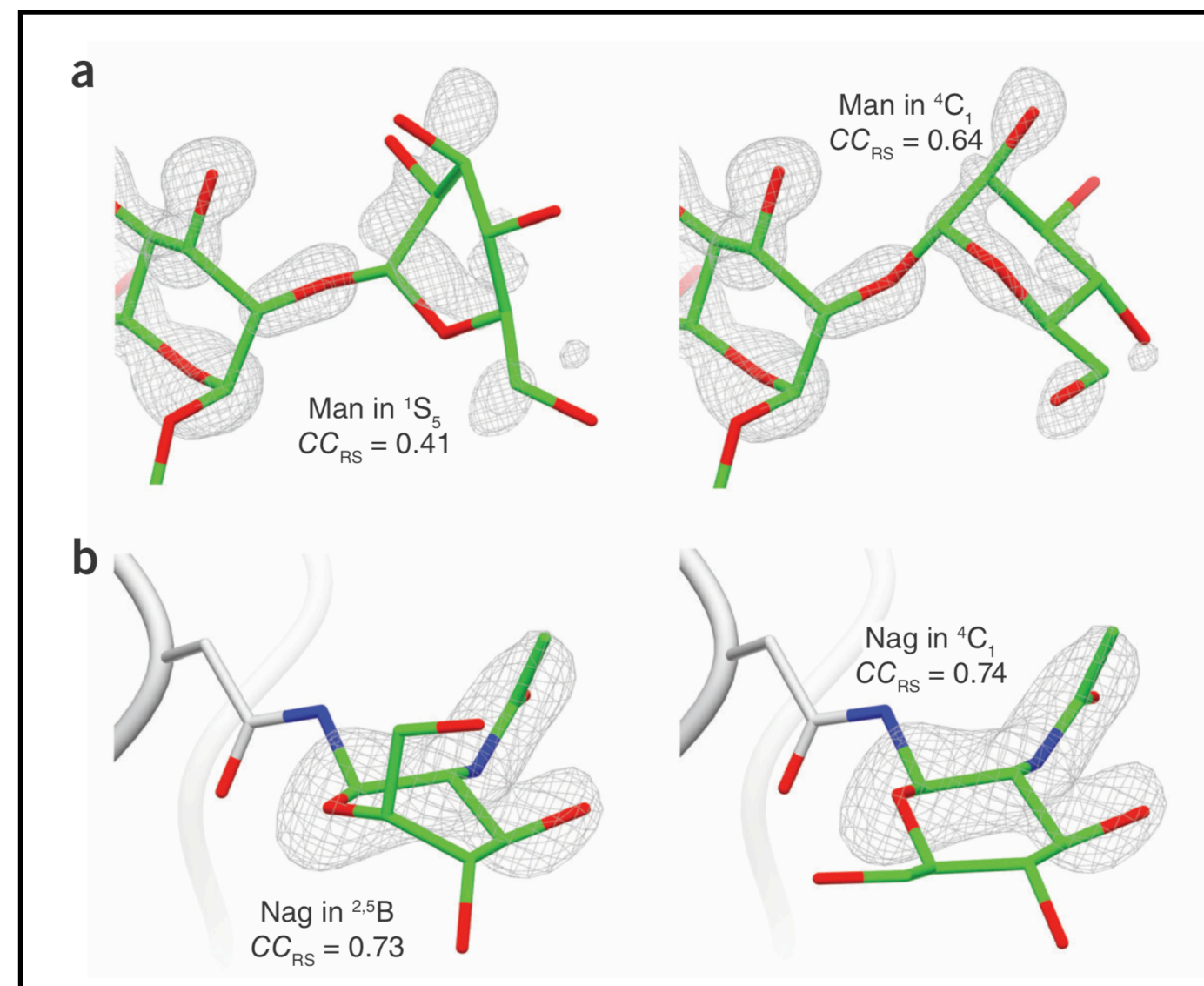

Agirre, Davies, Wilson & Cowtan, 2015, *Nature Structural & Molecular Biology* 22(11):833-834.

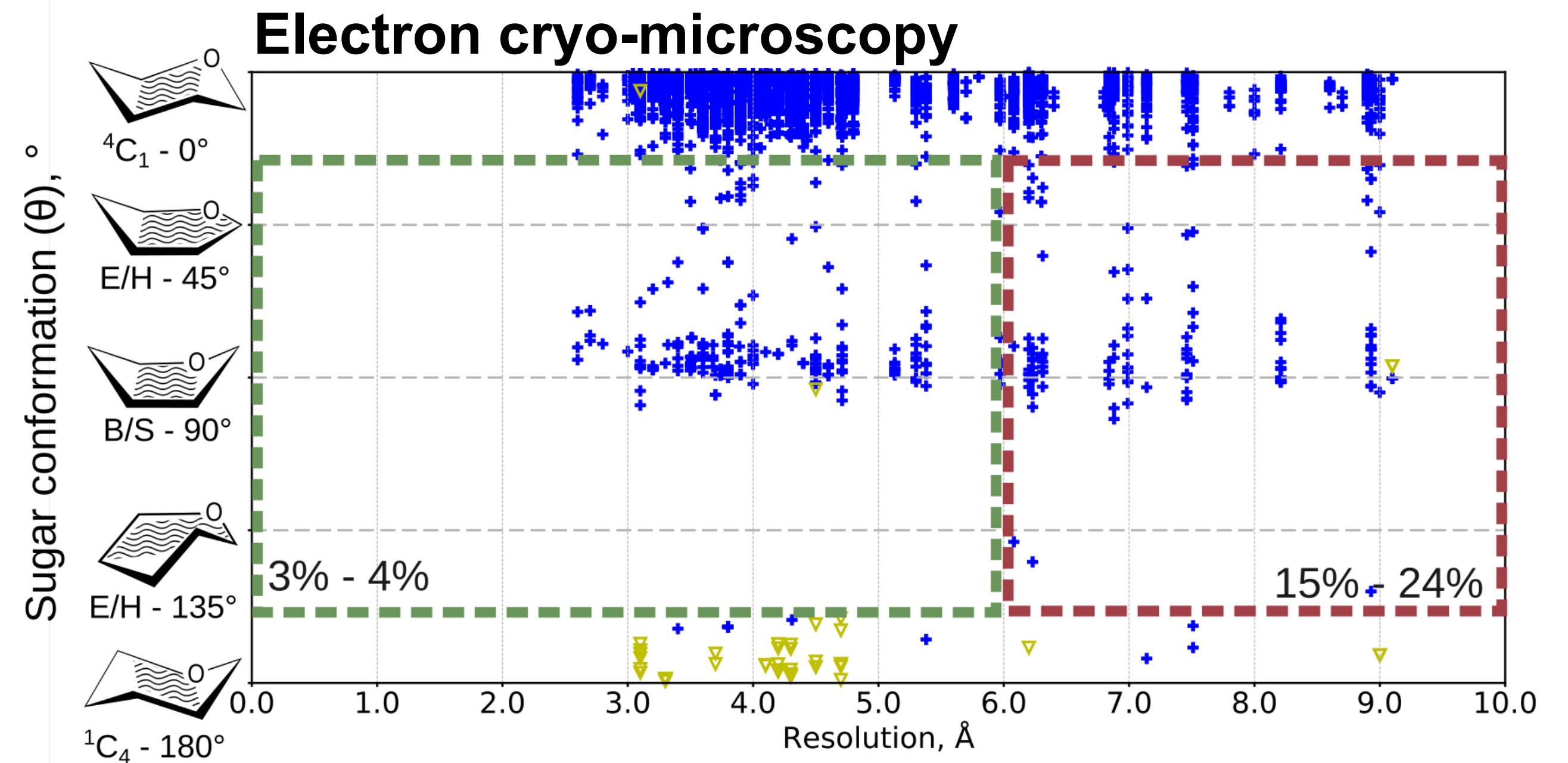
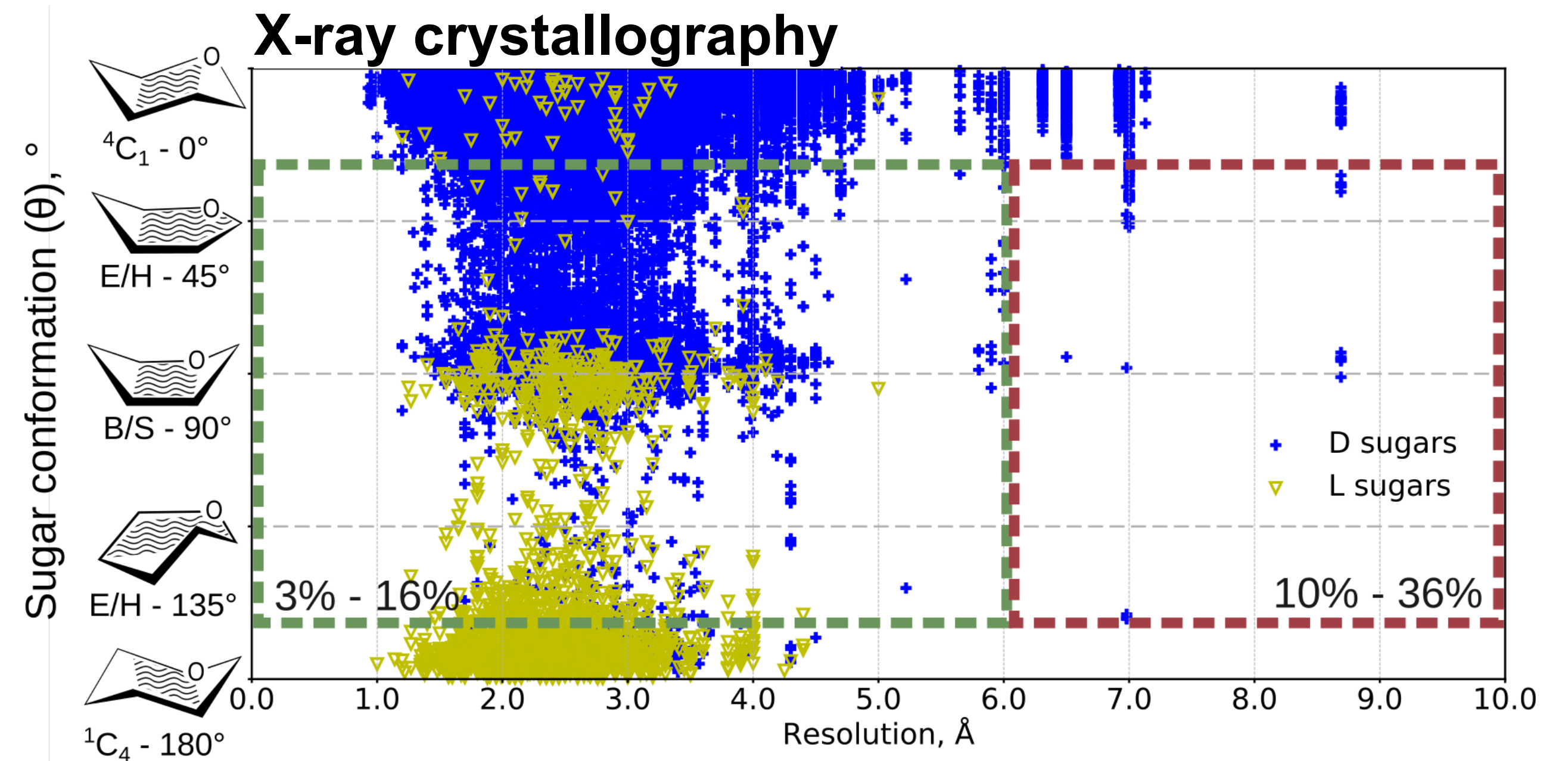

Atanasova, Bagdonas & Agirre, 2020, *Current Opinion in Structural Biology* 62:70-78.

Validation of structure, ring and link conformation of carbohydrate structures (MKIV)

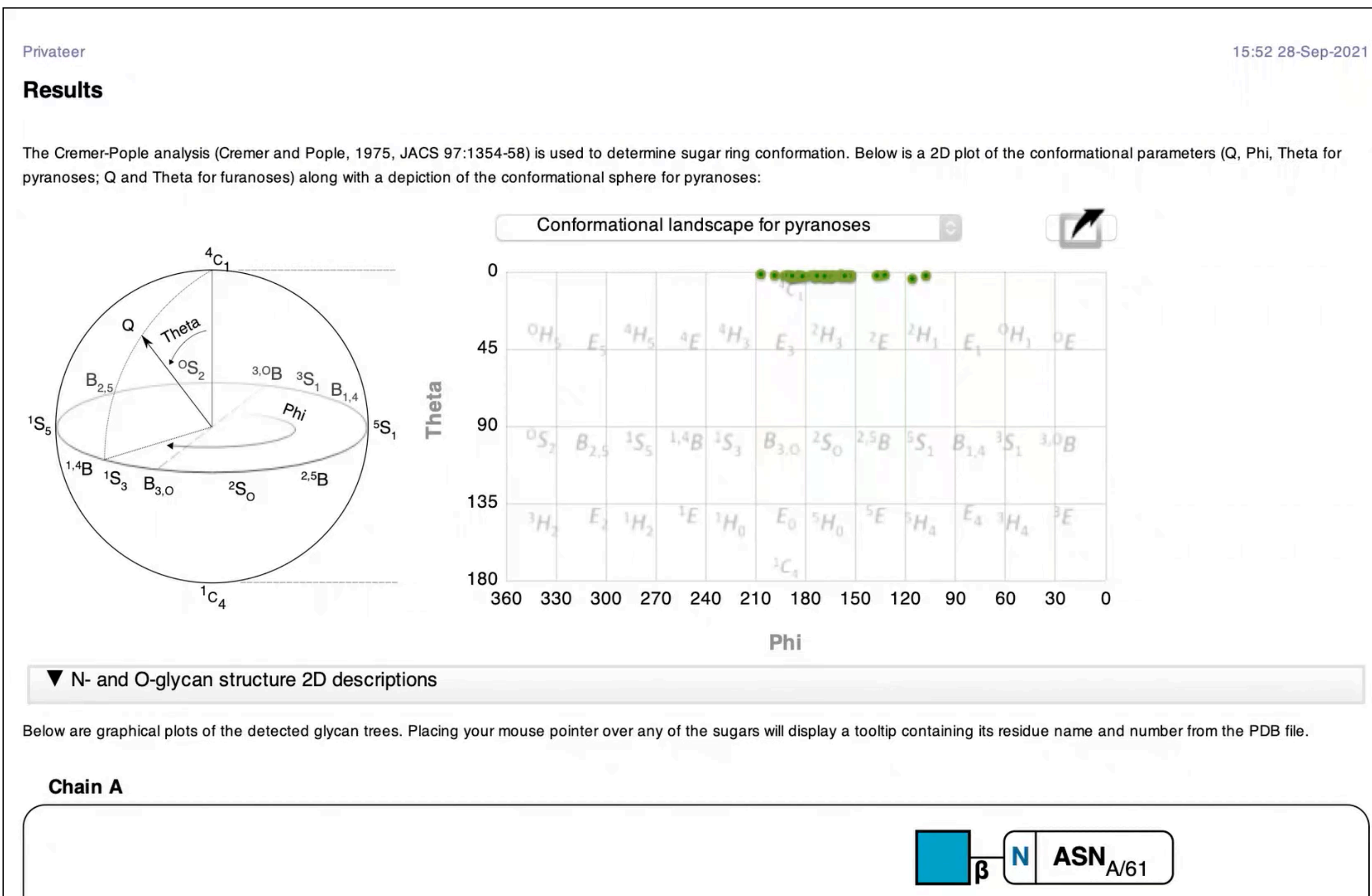

Bagdonas, Ungar & Agirre, 2020, Beilstein Journal of Organic Chemistry, 16(1):2523-2533.

Privateer

Available in CCP4 8.0 and CCP-EM
Web server: <http://privateer.york.ac.uk>

Or build it yourself: <https://github.com/glycojones/privateer>

Dictionaries for model improvement (MKIV)

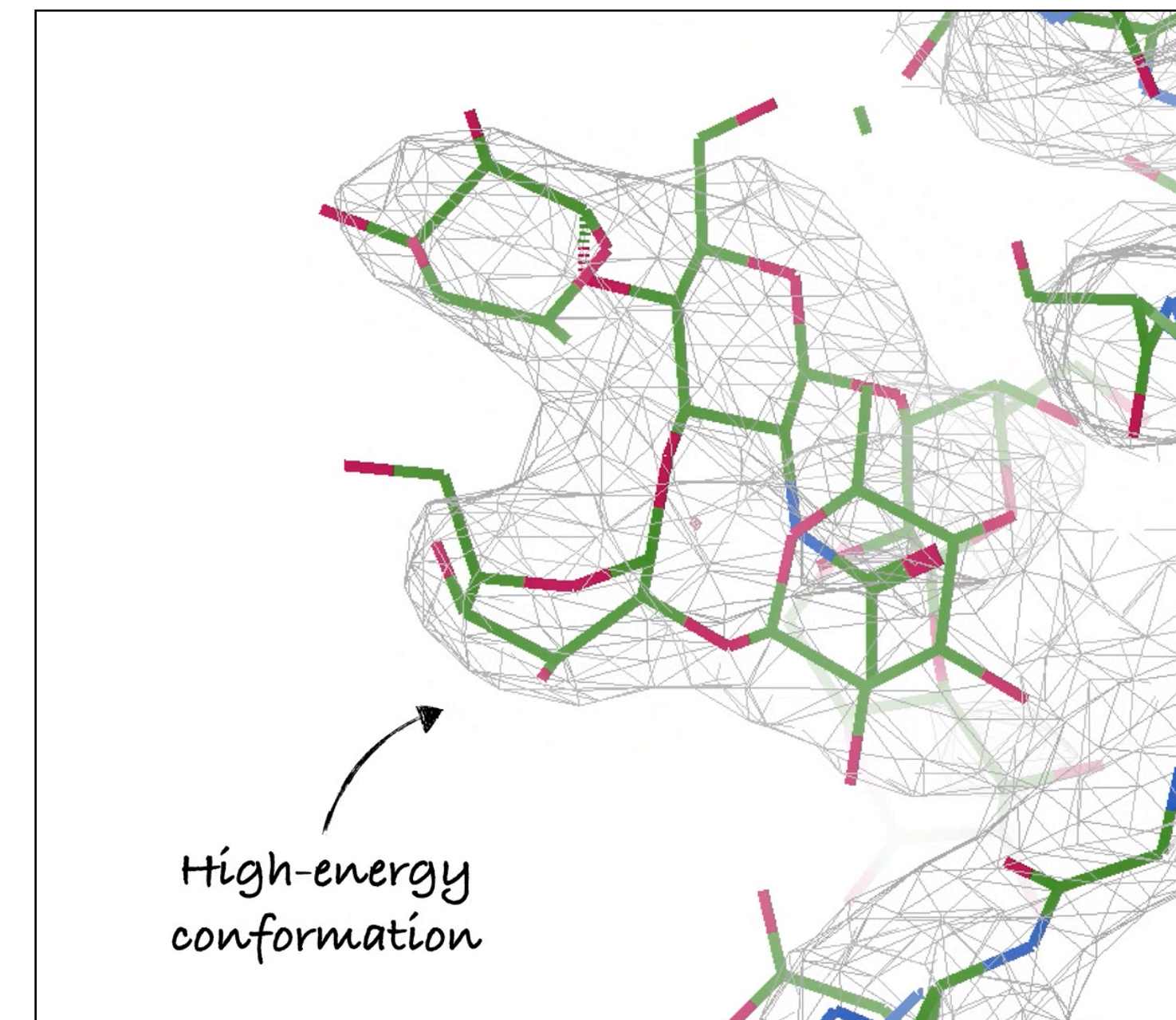

Linkage torsion validation (MKV)

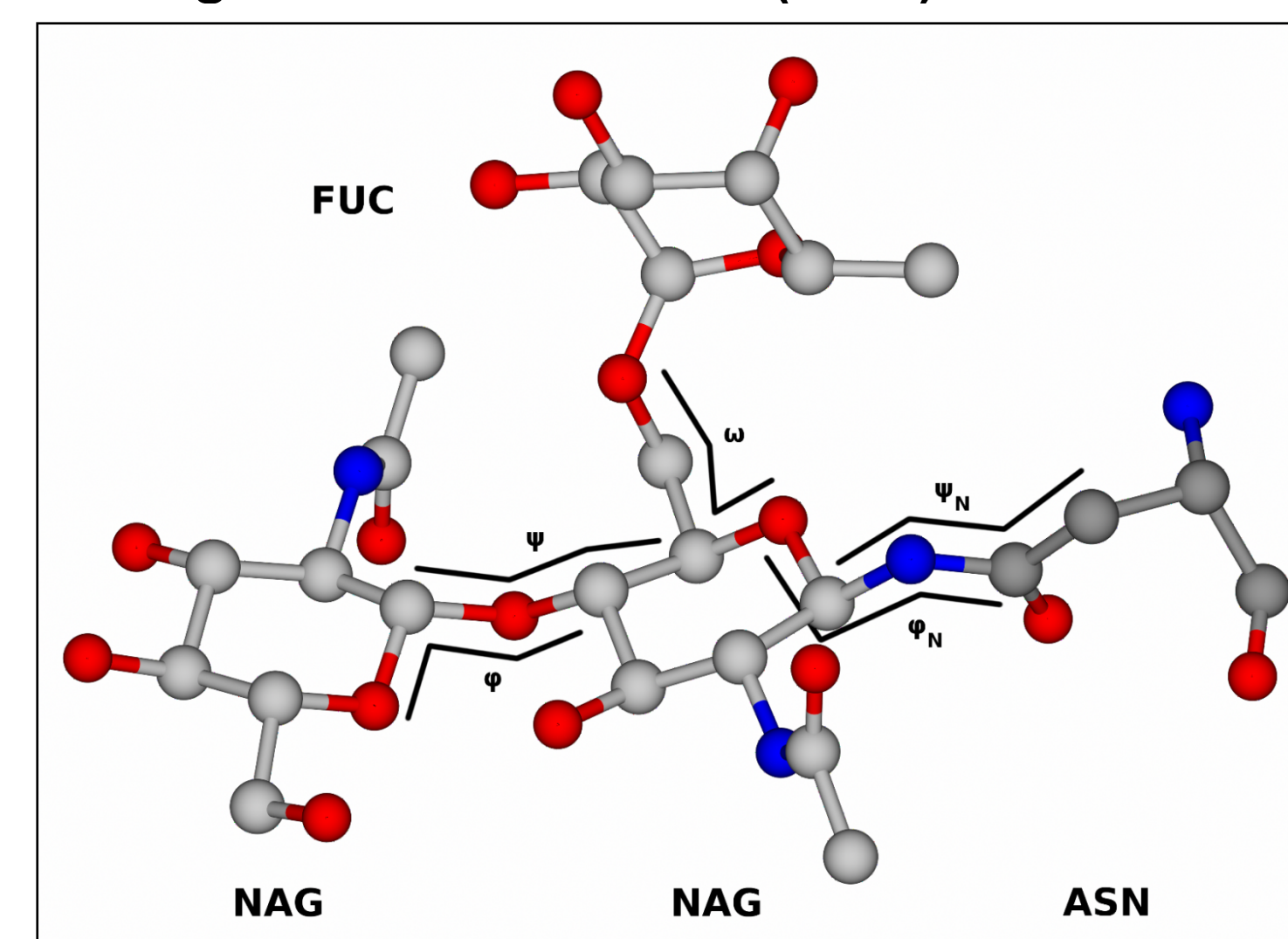

The Privateer software

- Has been useful in **every relevant context** where structural glycobiology has played a role: biofuels, immunology, cancer, fecundation and, of course, viral glycoproteins (HIV, Ebolavirus, Influenza, MERS, SARS-CoV-1 & 2).
- COVID-19 pandemic: used in constructs informing **mRNA vaccine design**, structures of **spike-antibody complexes** and **neutralising drugs**. Integrated in several analysis and validation pipelines.
- Released with main UK structural biology software suites: CCP4 and CCP-EM as well as being available as a Web App (<https://privateer.york.ac.uk/>) and in *Moorhen*.
- Open source available at <https://github.com/glycojones/privateer>

Glycomics powered validation

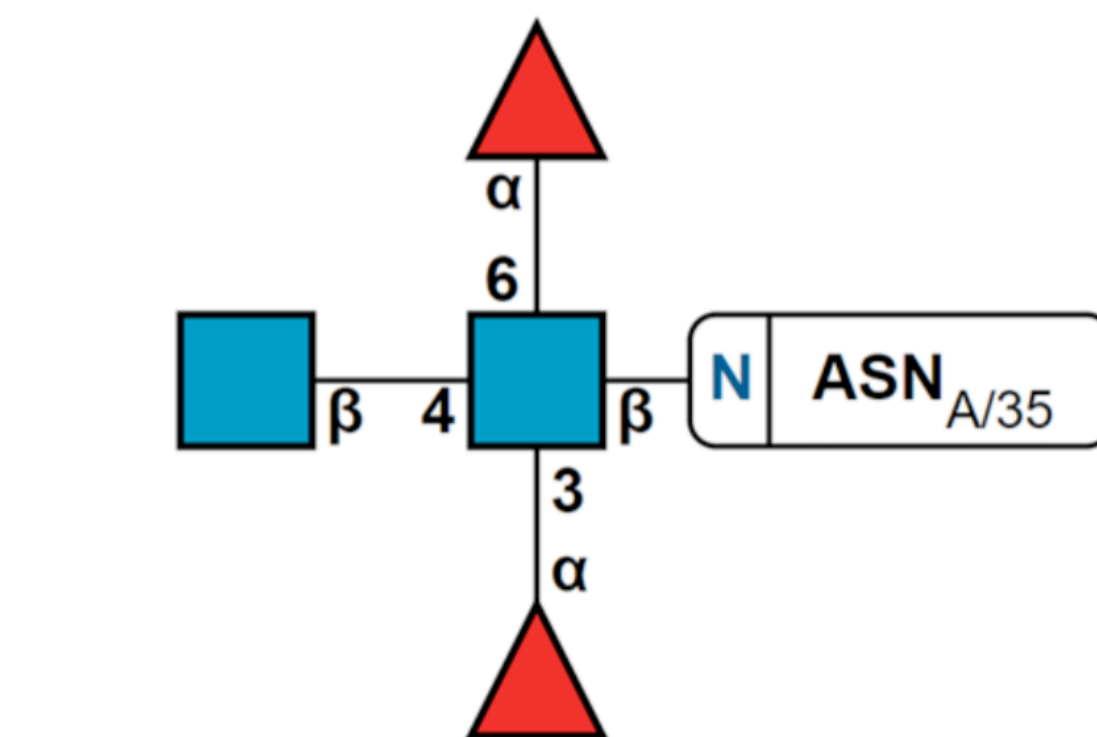
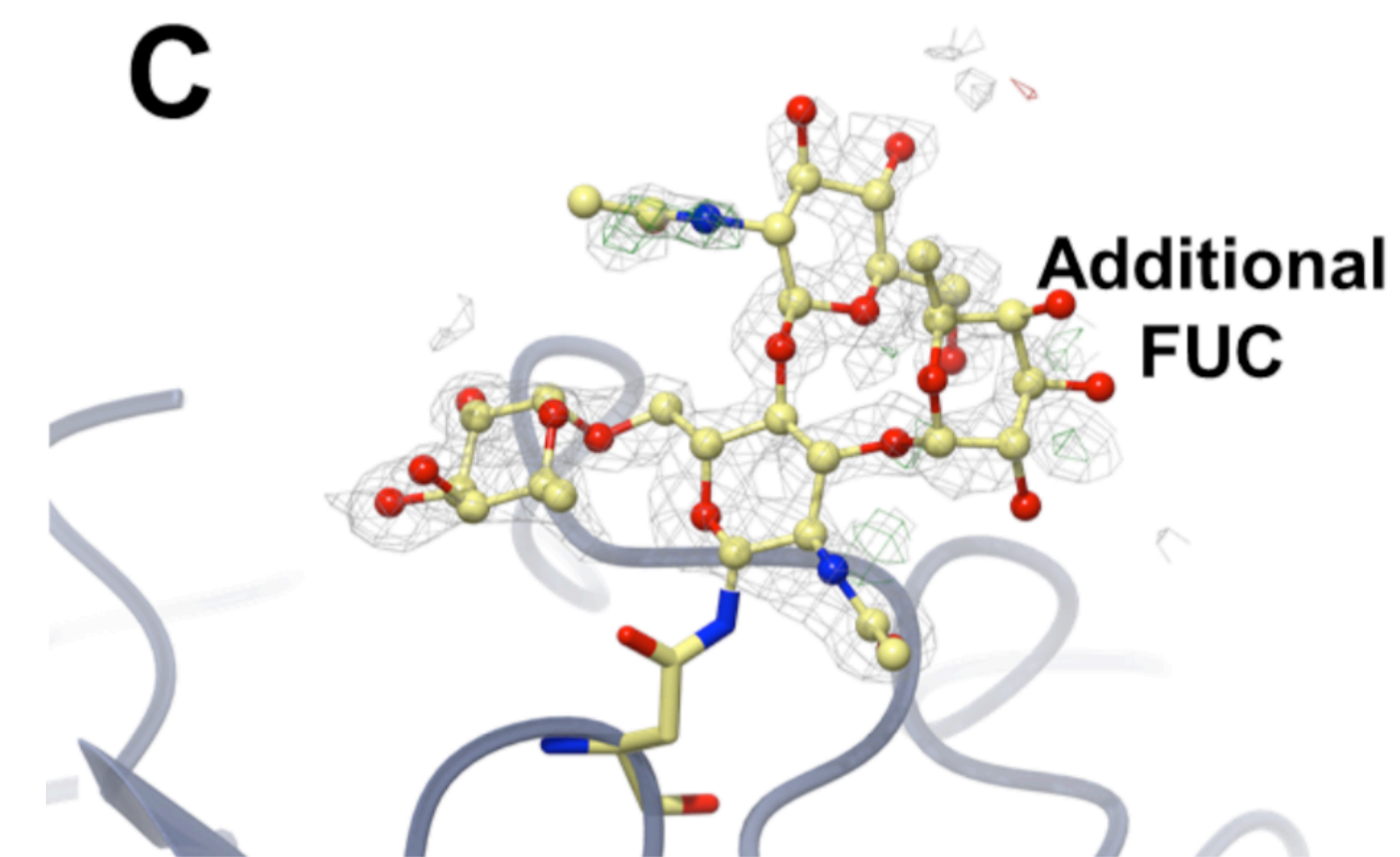
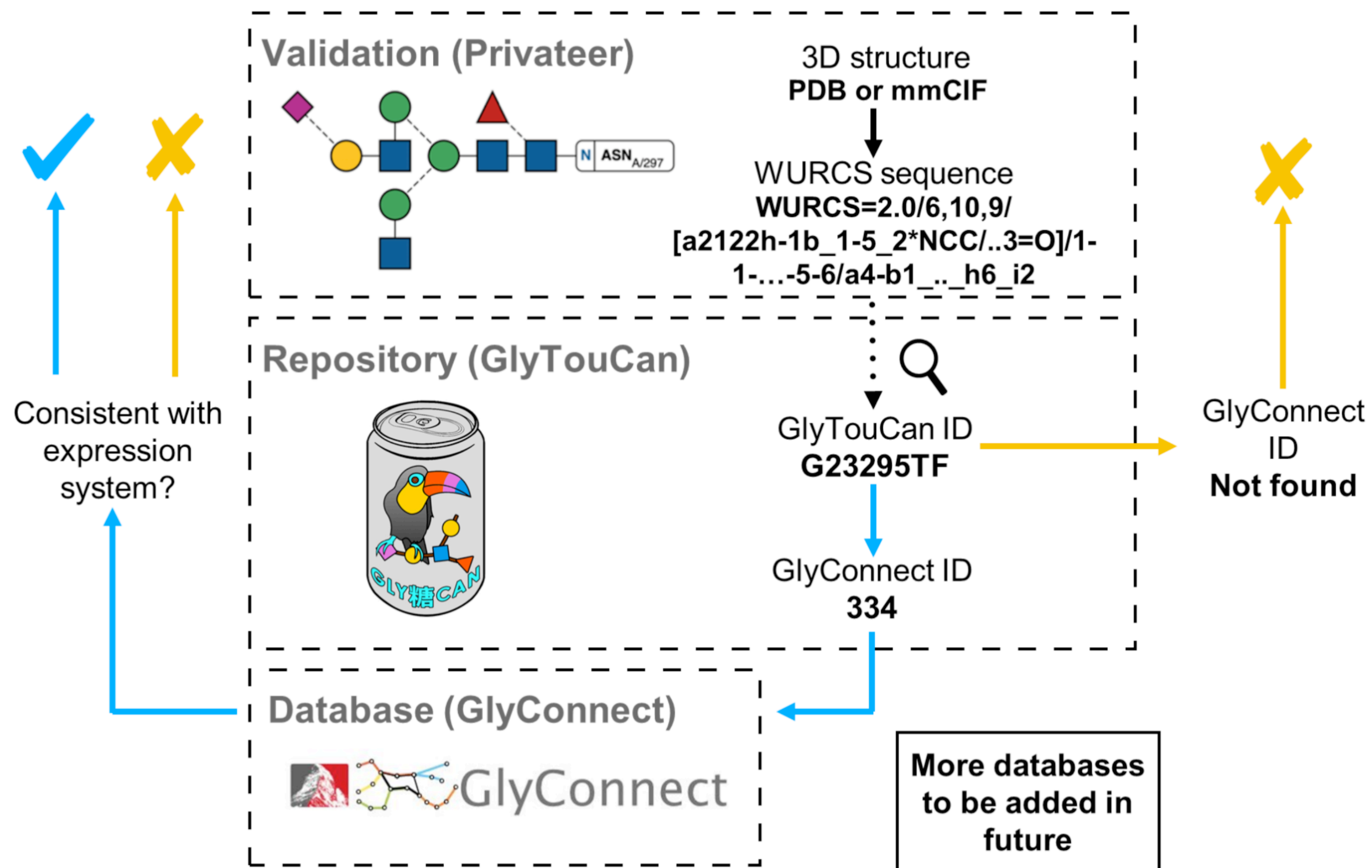

WURCS=2.0/2,4,3/[a2122h-1b_1-5_2*NCC/3=O][a1221m-1a_1-5]/1-2-1-2/a3-b1_a4-c1_a6-d1

GlyTouCan ID: **G63564LA**
 GlyConnect ID: **145**

Running Privateer (CCP-EM Doppio)

lah583@UOY24M013 Project: ~/ccpem-project CCP-EM Doppio

PROJECT JOBS NODES **NEW JOB** RESULTS LOGS I/O **OPTIONS** Job 8 - Privateer ✓

Filter jobs by name or description Expand all

- Atomic Model Build
- Atomic Model Fit
- Atomic Model Refine
- Atomic Model Split
- Atomic Model Utilities
- Atomic Model Validation
- Automated Class Selection
- Create Ligand
- Deposition
- Difference Map
- External
- Fetch
- Import
- Map Utilities
- Subset Selection
- Workflow

Job type: privateer.atomic_model_validation.glycans

Input model: Privateer/job007/InputFiles/7zcx.cif

Input map: Privateer/job007/InputFiles/emd_14635.map

Resolution: 3.1

Mask radius: 2.5

Validate against: undefined

Check in Glytoucan/Glyconnect? Yes No

Find closest match? Yes No

Generate all permutations for search? Yes No

Undefined sugar present? Yes No

Analyse sugar with code:

Sugar anomer: alpha

Sugar handedness: -D-

Ring conformation: pyranose

Pyranose conformation: 4c1

Furanose conformation: 3t2

Atom code of anomeric Oxygen: O5

Atom code of ring C1: C1

Accessing Privateer via Web App

<https://privateer.york.ac.uk/>

Validate your carbohydrates online with

Privateer

The Swiss Army knife for carbohydrate structure validation, refinement and analysis

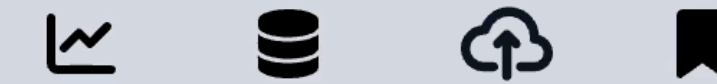

Choose a file
PDB, mmCIF or MTZ.
Files will never be sent externally.

OR

Fetch from PDB

Fetch

How does it work?

Carbohydrates, including O- and N-glycans attached to protein and lipid structures, are increasingly important in cellular biology. Crystallographic refinement of sugars is, however, very poorly

Accessing Privateer via Moorhen

The image shows the Privateer software interface, which is accessed via Moorhen. The interface consists of a vertical toolbar on the left side with the following options: File, Edit, Calculate, View, Validation, Ligand, Map Tools, Models, Maps, History, Preferences, and Help. The main window displays a 3D molecular model of a protein-ligand complex. The protein is represented as a grey surface, and the ligand is shown as a stick model. A mouse cursor is visible near the bottom center of the model.

New carbohydrate dictionaries

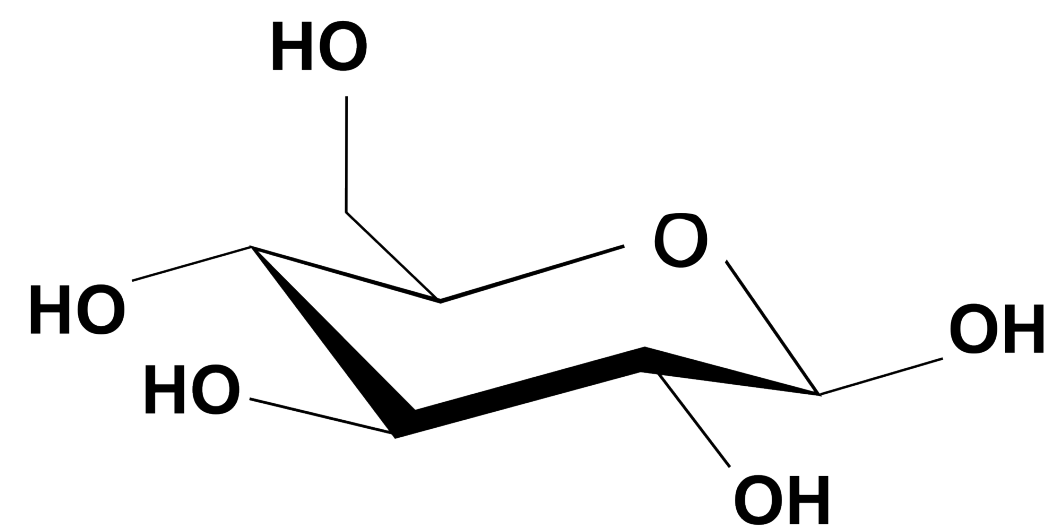

chemical description

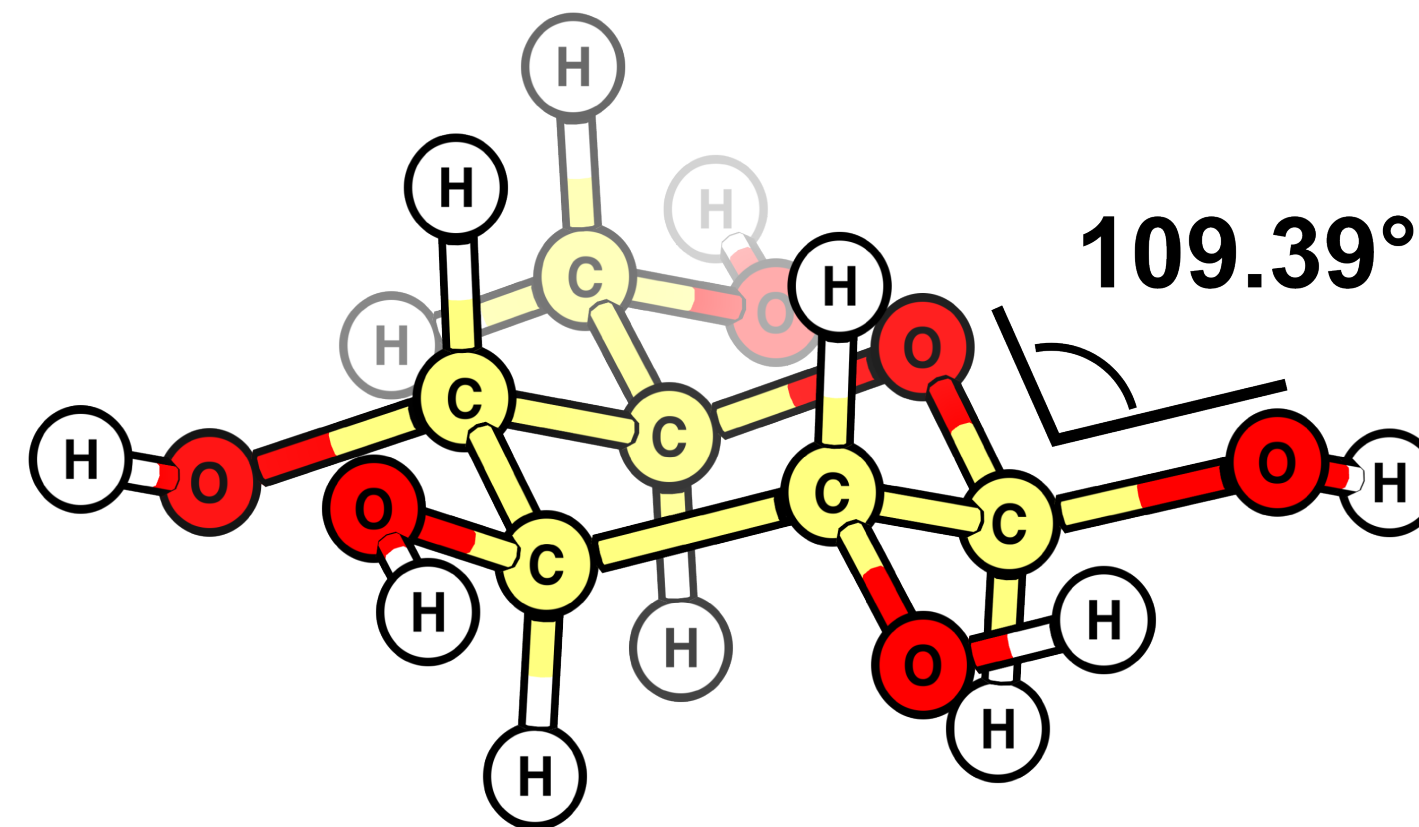
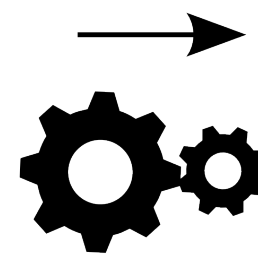

restraints & coordinates

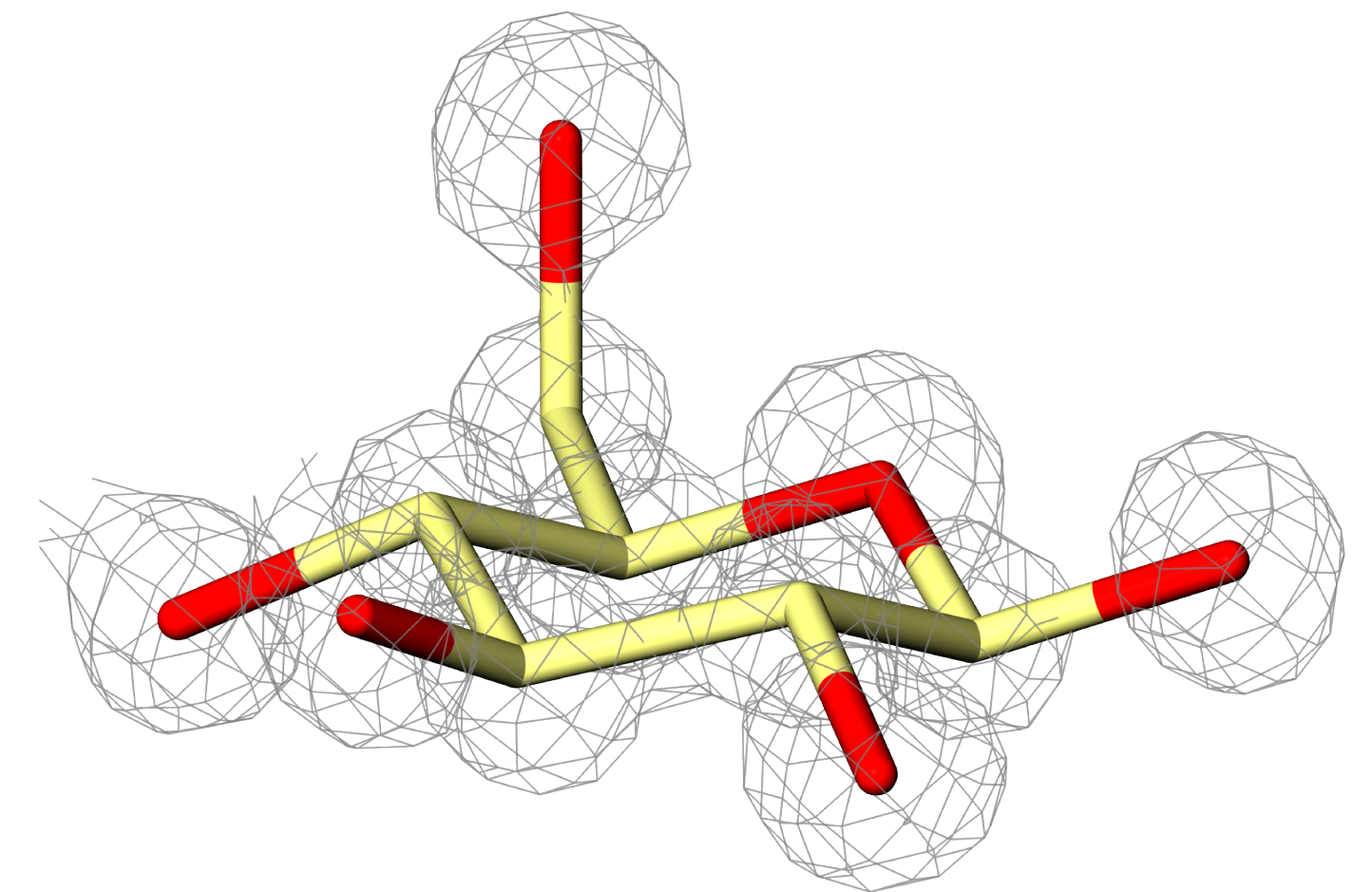
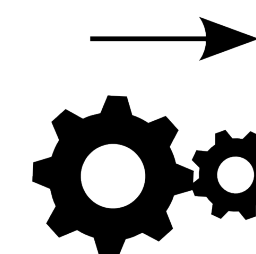

fitted model

```
$PATH_TO_EXECUTABLE/privateer -pdbin filename.pdb -external_restraints
```

New carbohydrate dictionaries

All this information to restrain one GlcNAc

Compound definition, with **3-letter code**, **full name**, **type** and number of atoms, **all** and **non-hydrogen**

```
NAG      NAG  'N-ACETYL-D-GLUCOSAMINE'      pyranose      30  15  .
```

Atom by atom definition of the conformer, with **name**, symbol, charge and **cartesian coordinates**

```
NAG      O1      O      OH1      0.000      1.203      0.420      0.648
```

A bond between a **pair of atoms**, **cardinality**, **expected distance** and **standard deviation**

```
NAG      O1      C1      single      1.432      0.020
```

An angle between **three atoms**, with **expected value** and **standard deviation**

```
NAG      O1      C1      C2      109.470      3.000
```

A **torsion angle** between **four atoms**, with **expected value**, **standard deviation** and **periodicity**

```
NAG      var_7      C5      C4      C3      C2      60.000      20.000      3
```

A **chiral volume**, defined by **four atoms** in a tetrahedral arrangement, and a **sign defining orientation**

```
NAG      chir_01      C1      C2      O1      O5      positiv
```

A **series of atoms** taking part of a **planar arrangement**, plus **standard deviation**

```
NAG      plan-2      N2      0.020
```

```
NAG      plan-2      C2      0.020
```

```
NAG      plan-2      C7      0.020
```

```
NAG      plan-2      HN2     0.020
```

3QVP - 1.2 Å

3U7Y - 2.4 Å

5UM8 - 3.9 Å

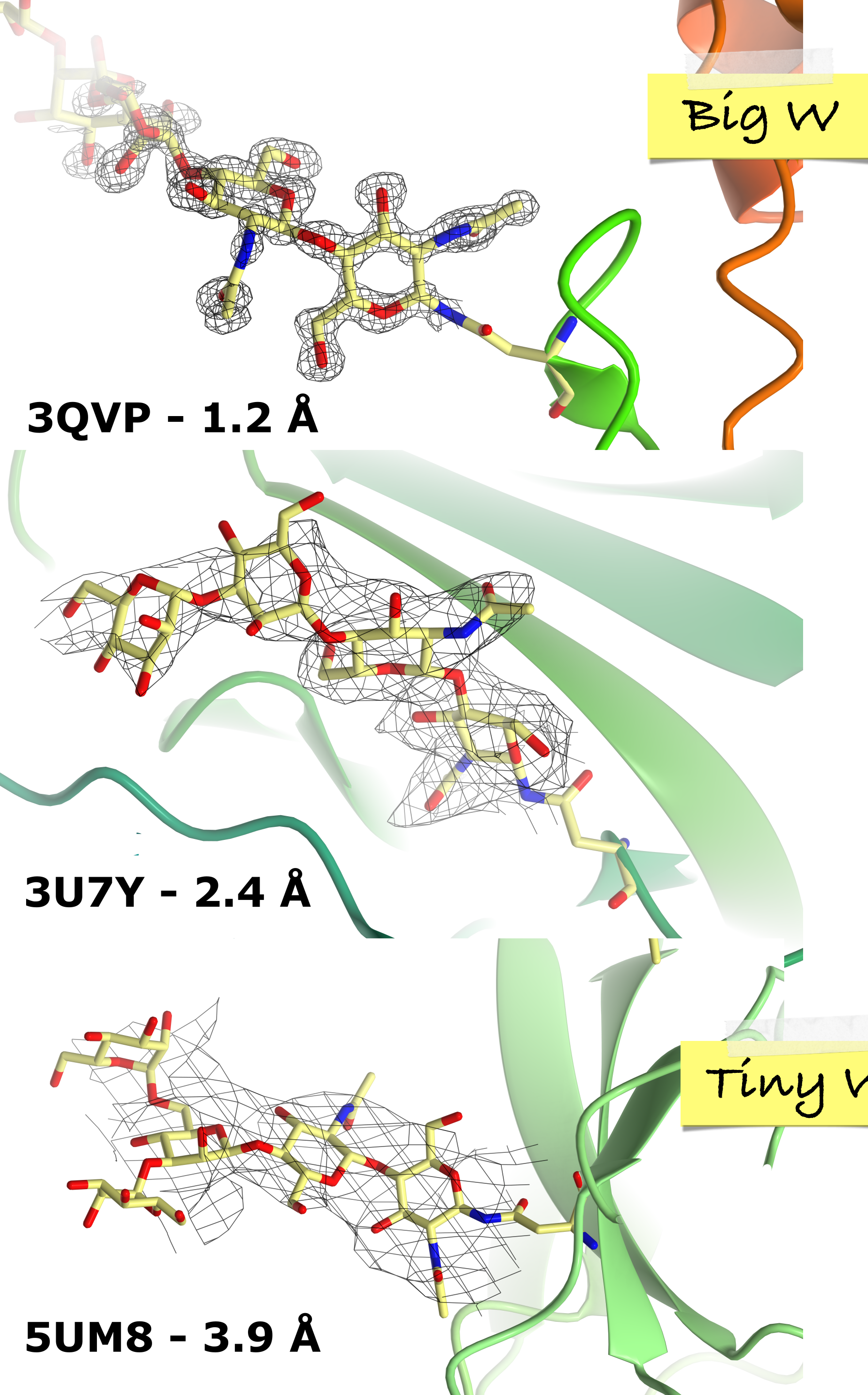

What about ring conformation?

With weak/incomplete density, a ring's lowest-energy conformation may have to be explicitly restrained:

$$L(p) = WLX(p) + LG(p)$$

Yes!
bond lengths

Yes!
bond angles

Yes!
Planar groups

?
harmonic torsions

?
NCS, etc

~60°/-60°

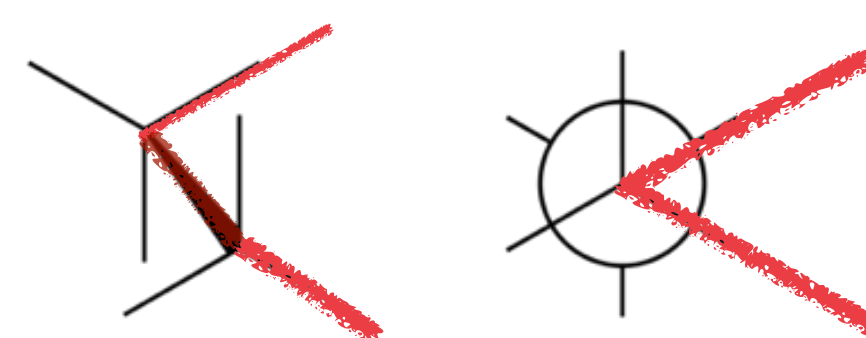

Staggered

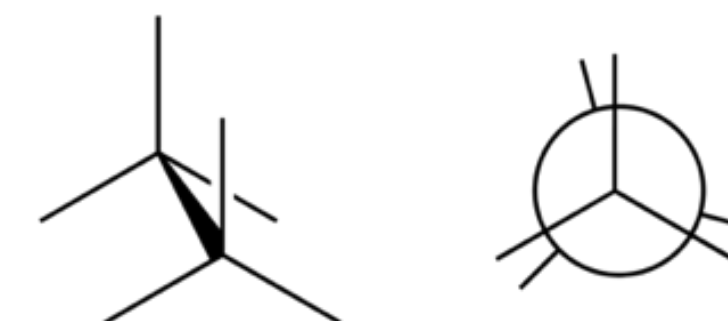

Eclipsed

Our new restraint dictionaries *understand* ring conformation

Patched `_chem_comp_tor` section of a restraint dictionary separating **ring torsion angles** from the **rest**, as specified by **four atoms**, **target value**, **uncertainty** and **periodicity**

NAG	ring_1	C5	O5	C1	C2	-59.675385	3.0	1
NAG	ring_2	O5	C1	C2	C3	53.650513	3.0	1
NAG	ring_3	C1	C2	C3	C4	-52.014420	3.0	1
NAG	ring_4	C2	C3	C4	C5	54.096725	3.0	1
NAG	ring_5	C3	C4	C5	O5	-56.921230	3.0	1
NAG	ring_6	C4	C5	O5	C1	61.200516	3.0	1
NAG	tors_1	C8	C7	N2	C2	-175.114227	10.0	2
NAG	tors_2	N2	C7	C8	H81	-13.703261	10.0	6
NAG	tors_3	C5	C6	O6	HO6	-177.520996	10.0	3
NAG	tors_4	C4	C5	C6	O6	61.135471	10.0	3
NAG	tors_5	C6	C5	O5	C1	-175.561295	10.0	3
NAG	tors_6	O4	C4	C5	C6	63.707928	10.0	3
NAG	tors_7	C3	C4	O4	HO4	-61.268230	10.0	3
NAG	tors_8	O3	C3	C4	O4	-63.830528	10.0	3
NAG	tors_9	C2	C3	O3	HO3	-169.485916	10.0	3
NAG	tors_10	C7	N2	C2	C1	124.894669	10.0	6
NAG	tors_11	N2	C2	C3	O3	61.918137	10.0	3
NAG	tors_12	C2	C1	O1	HO1	163.115189	10.0	3
NAG	tors_13	O1	C1	O5	C5	179.557251	10.0	3
NAG	tors_14	O1	C1	C2	N2	-62.214077	10.0	3

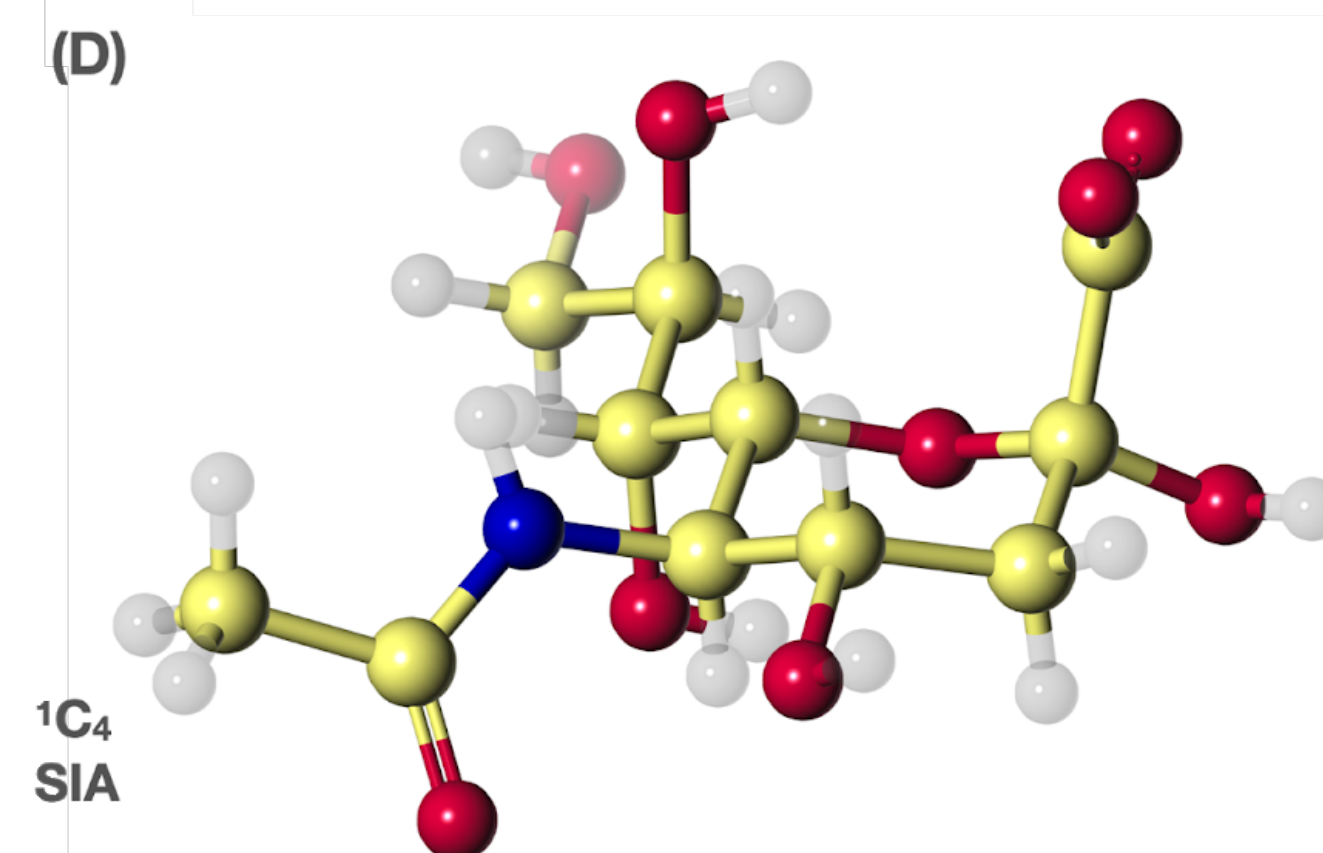
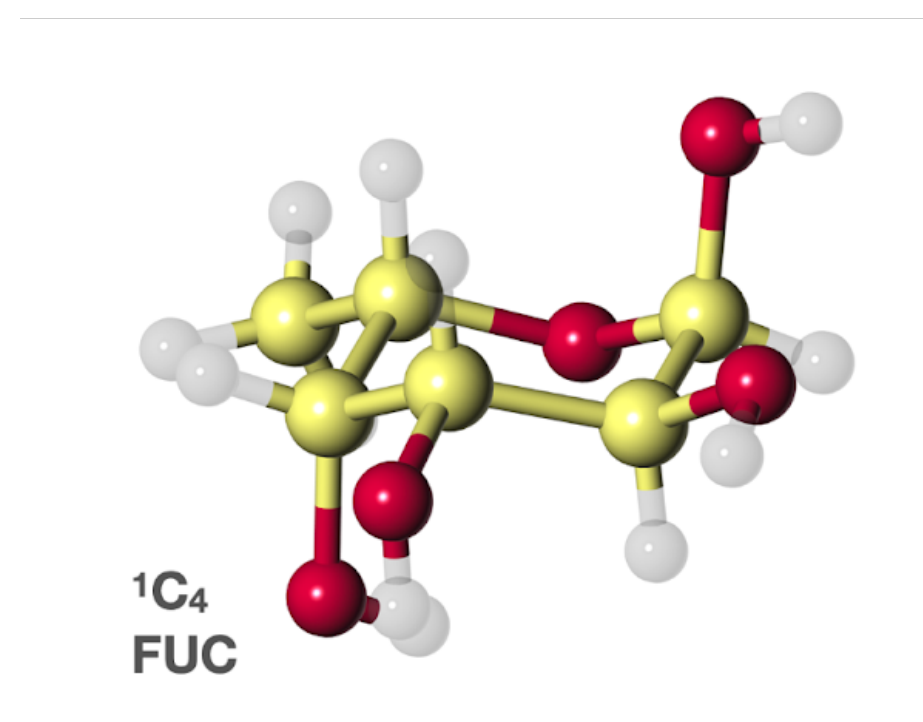
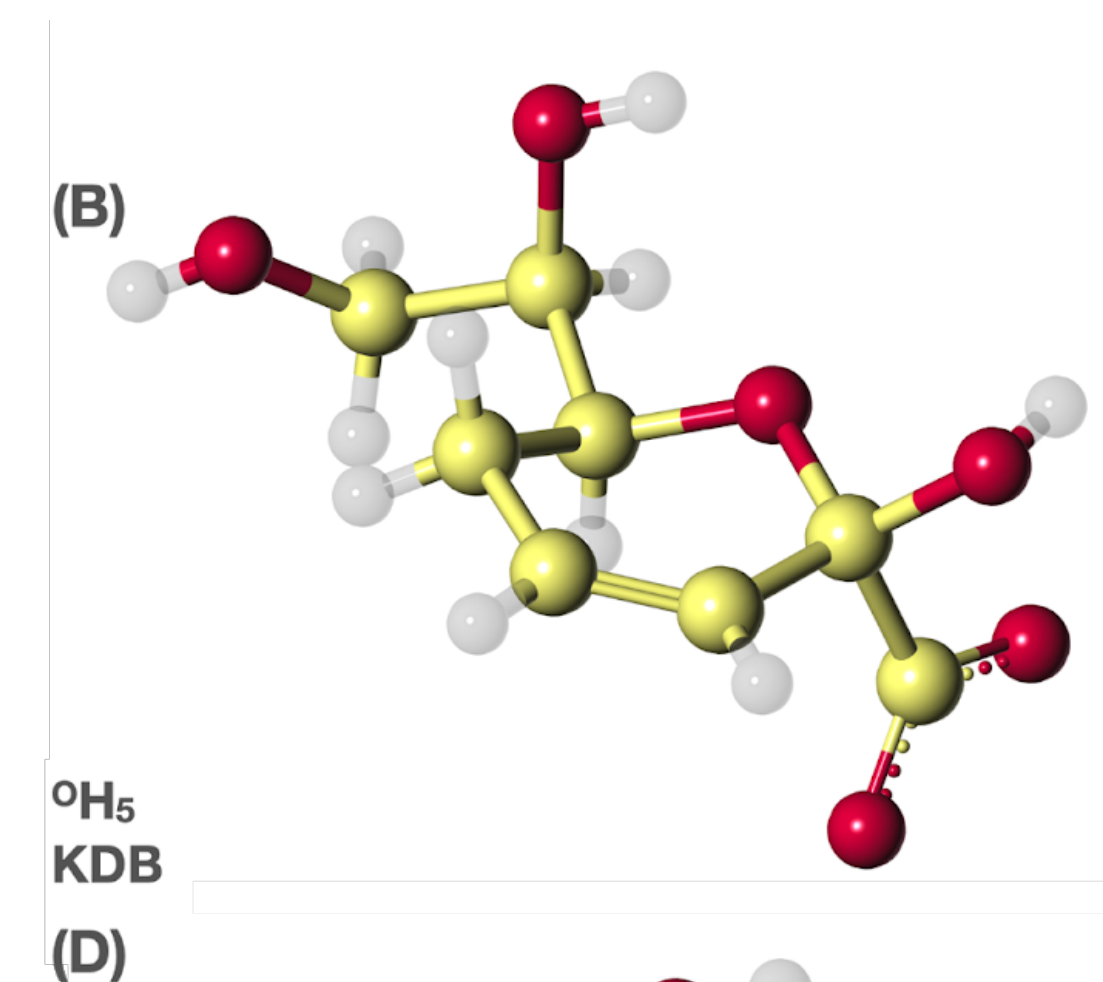
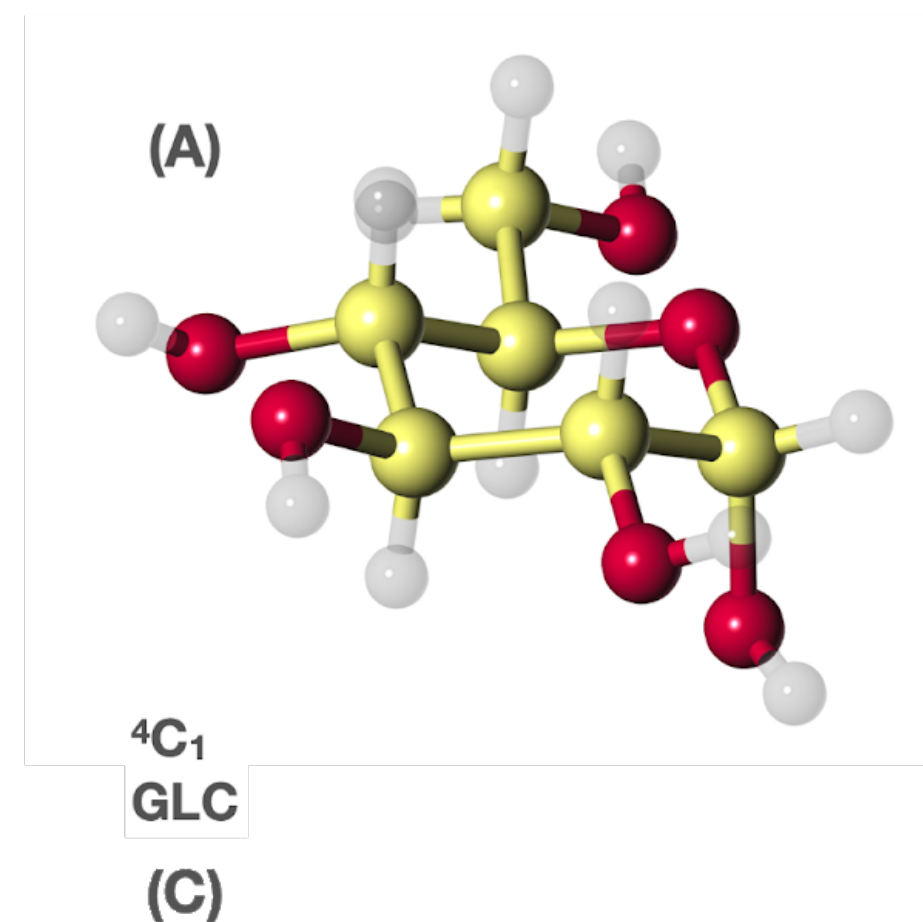

Conformational restraints N-glycosylation

No conformational distortions expected!

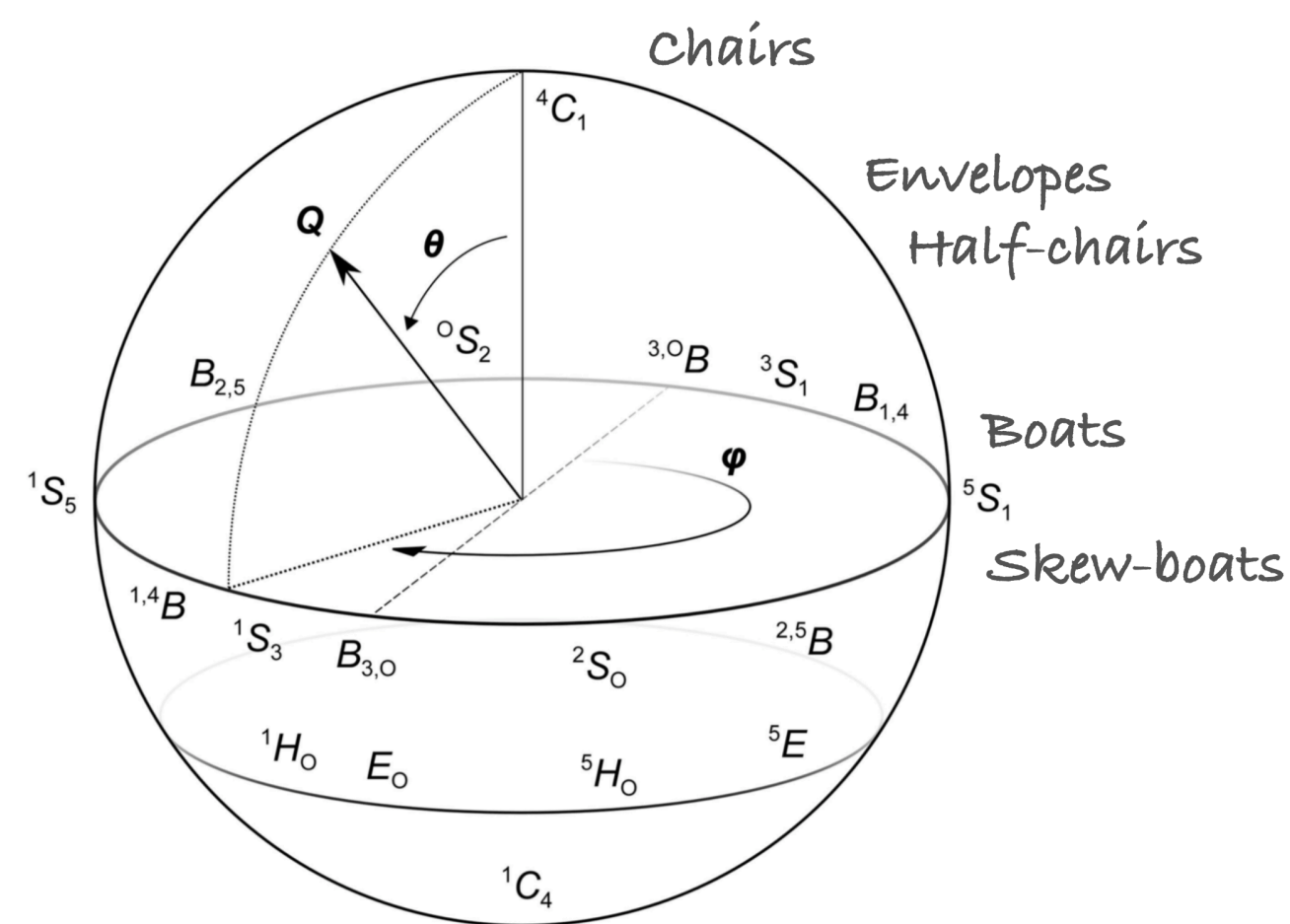

Atanasova, Joosten, Nicholls & Agirre, 2022,
Acta Crystallographica D(78):455-465

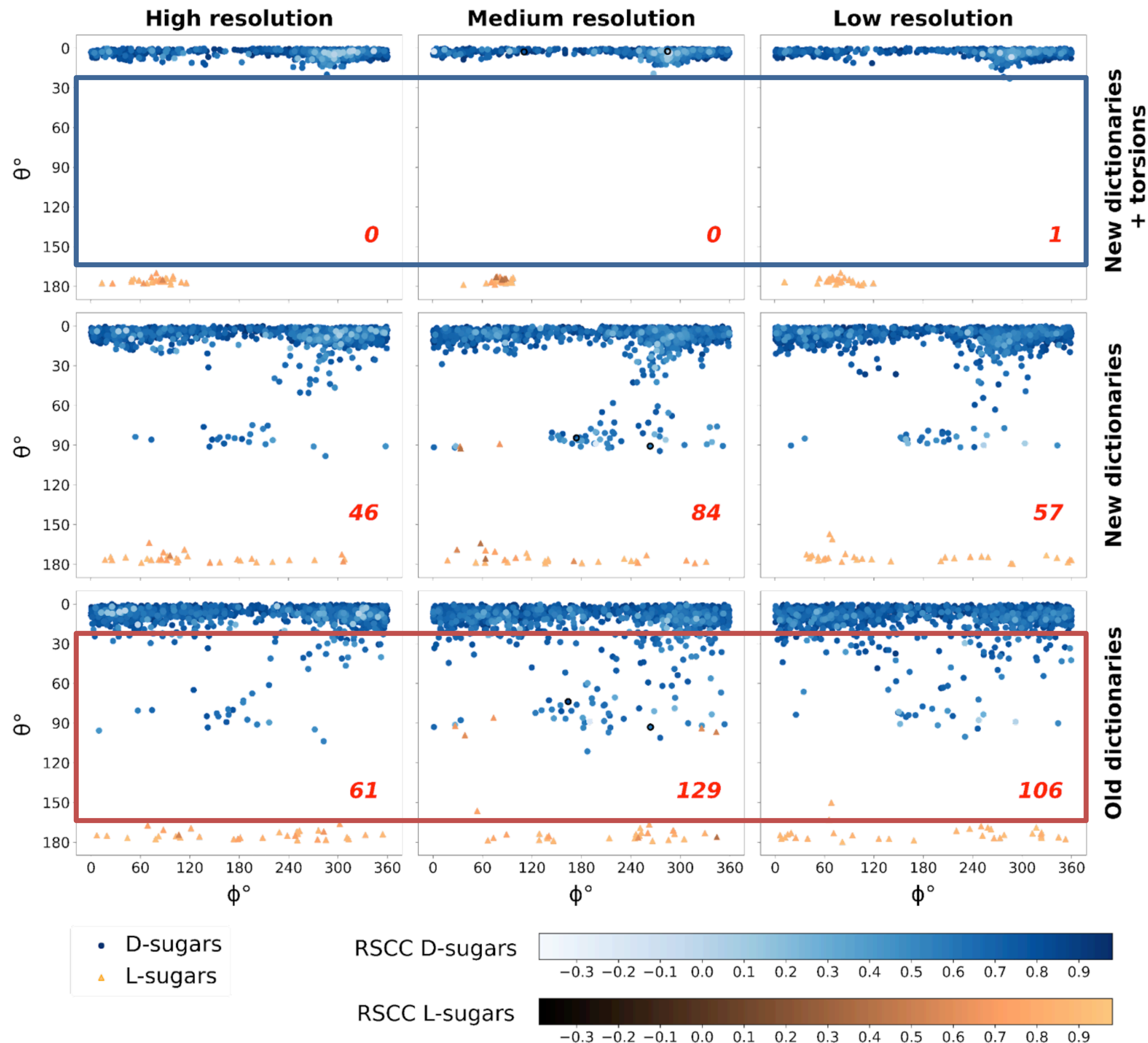

Conformational restraints Ligands

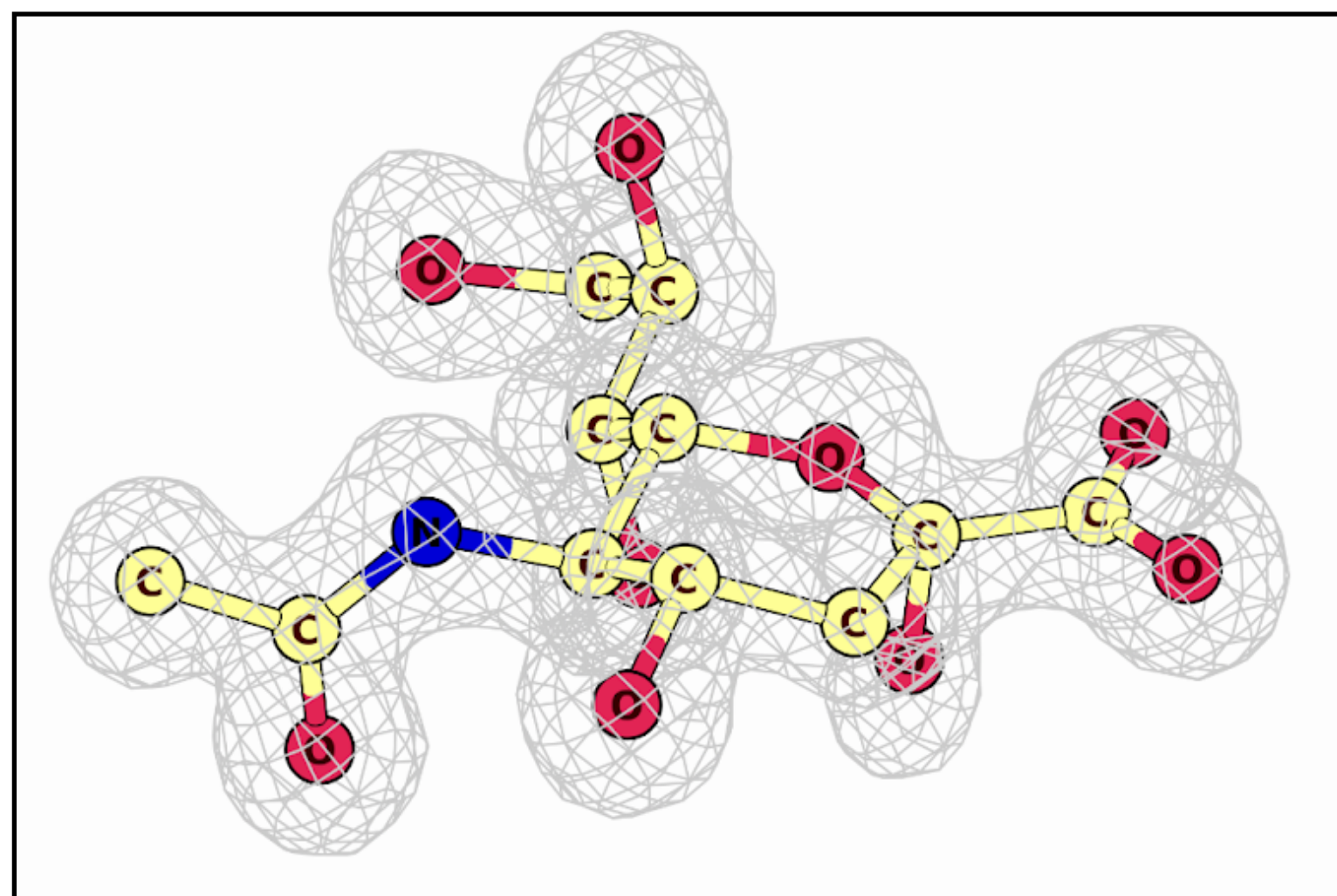

6HG0 (SIA-A-522) in 4E
1.30 Å resolution, RSCC=0.94

Atanasova, Joosten, Nicholls & Agirre, 2022,
Acta Crystallographica D(78):455-465

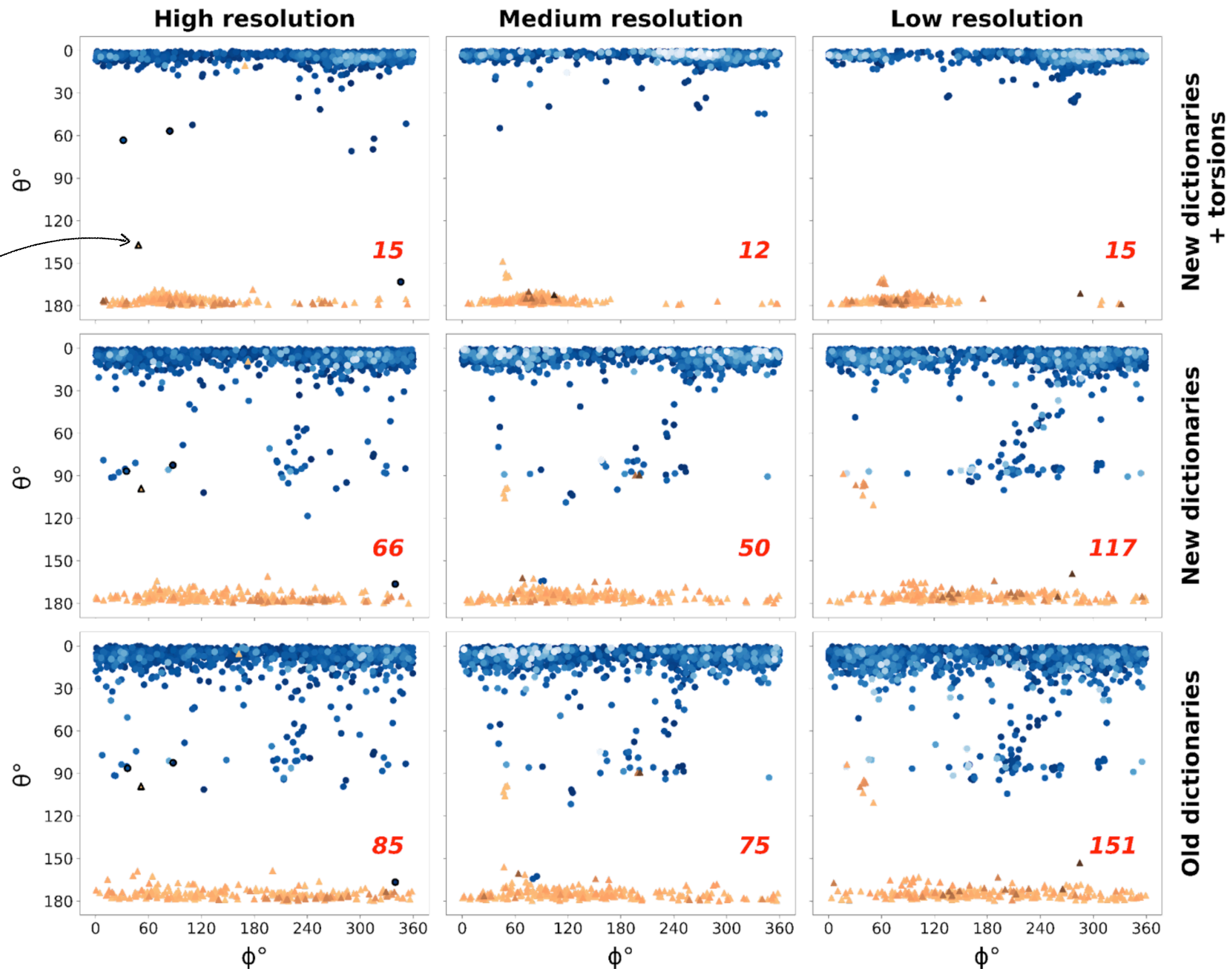

• D-sugars
 ▲ L-sugars

RSCC D-sugars

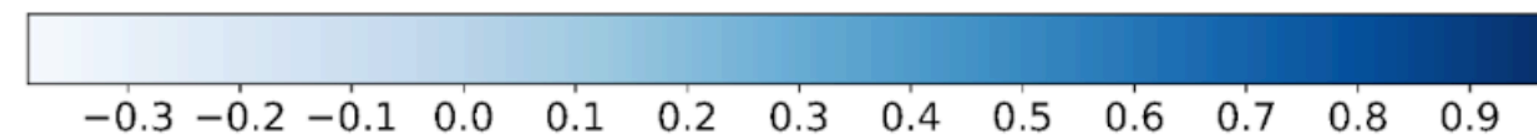

RSCC L-sugars

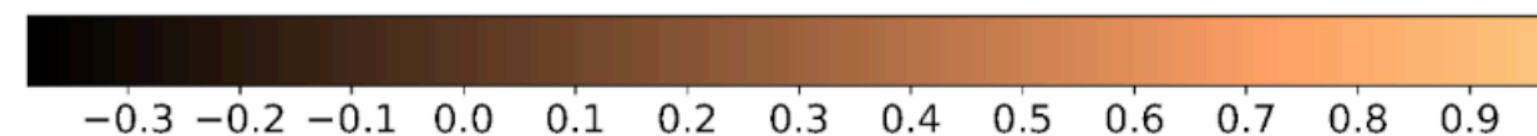

Conformational restraints Ligands

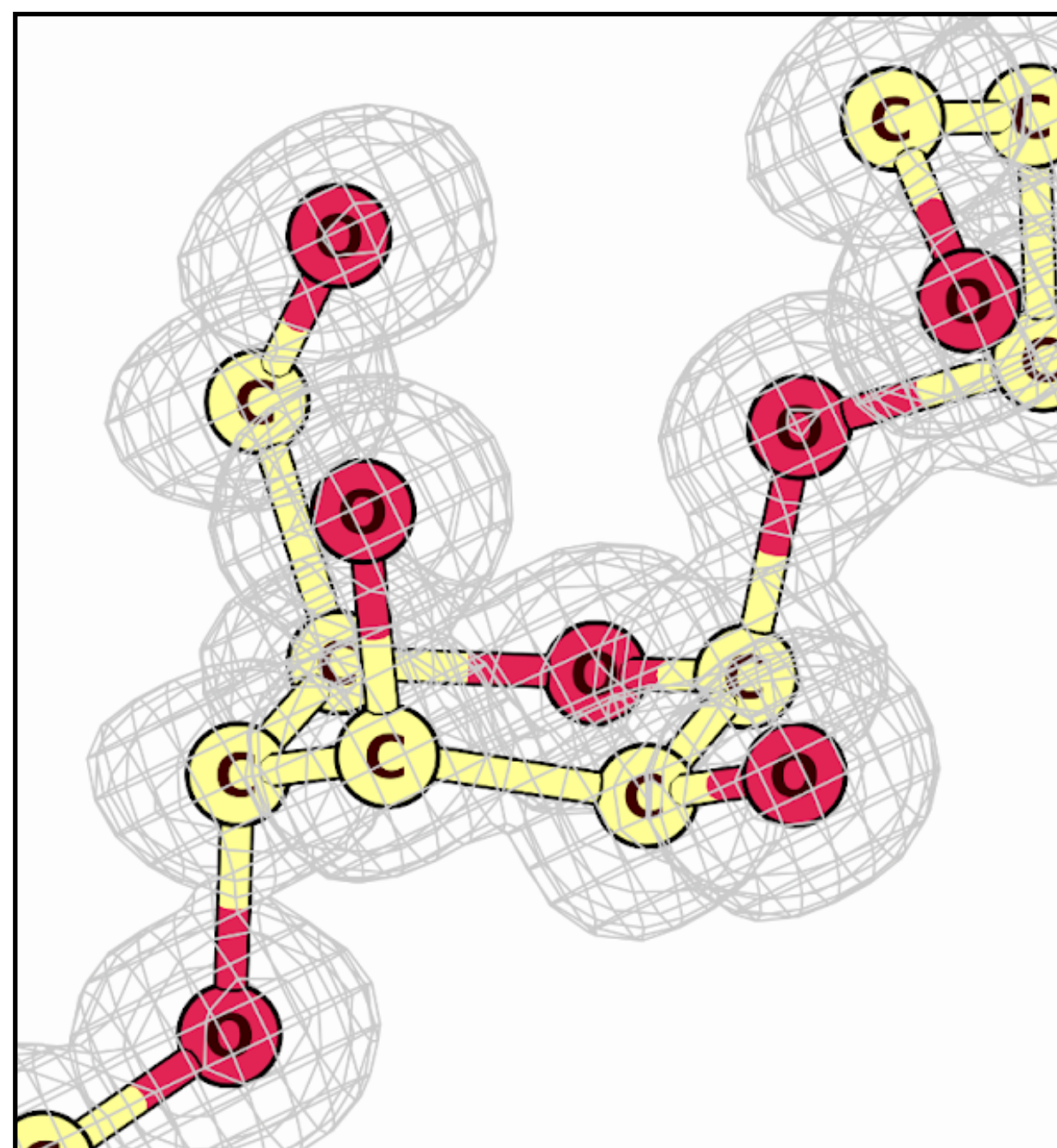

**5JUG (BMA-B-3) in 1C_4
0.95 Å resolution, RSCC=0.95**

*Atanasova, Joosten, Nicholls & Agirre, 2022,
Acta Crystallographica D(78):455-465*

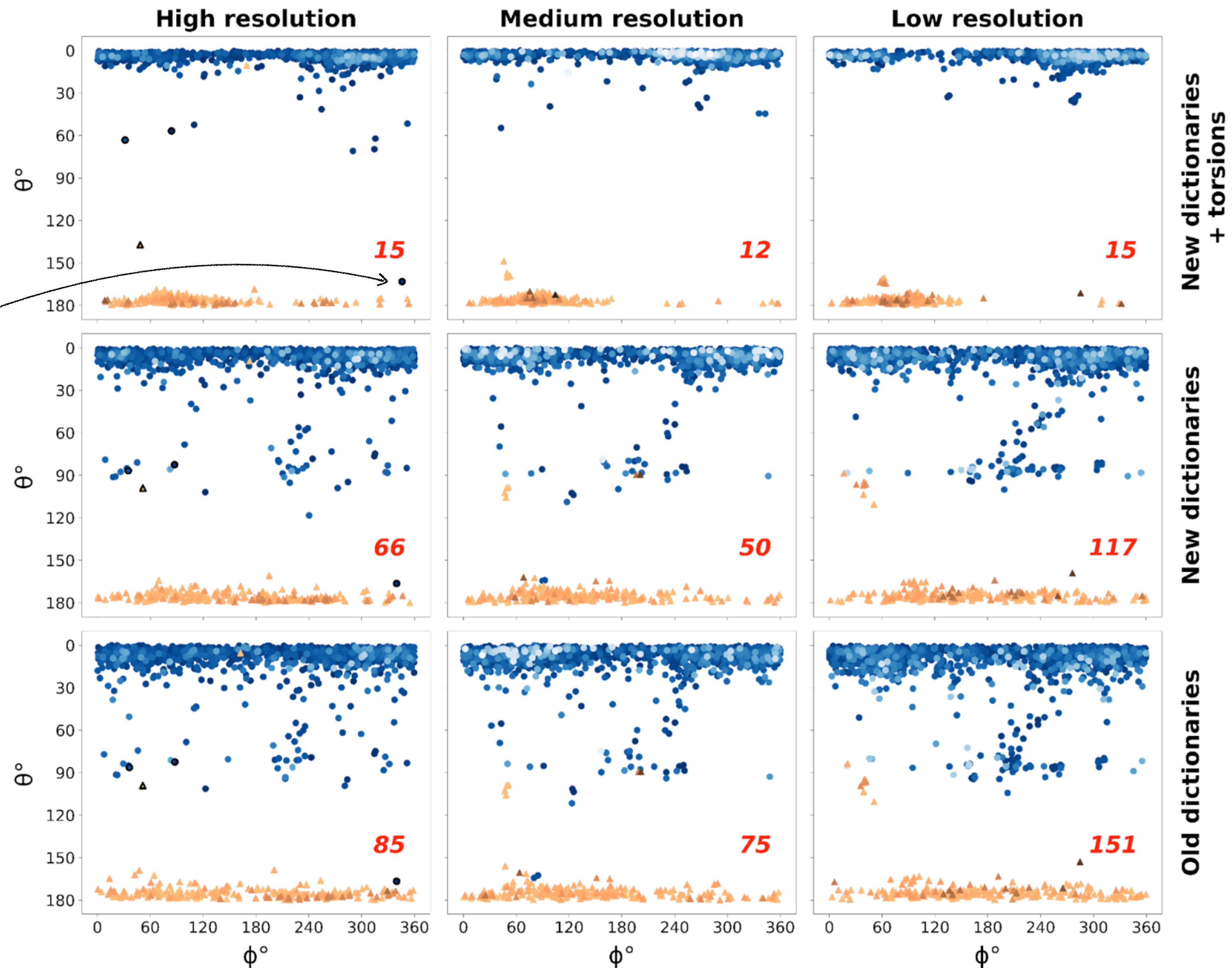

• D-sugars
▲ L-sugars

RSCC D-sugars

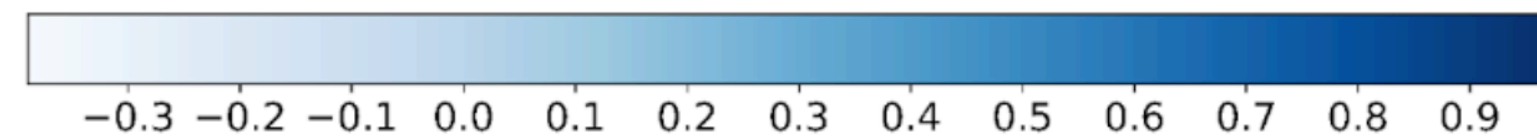

RSCC L-sugars

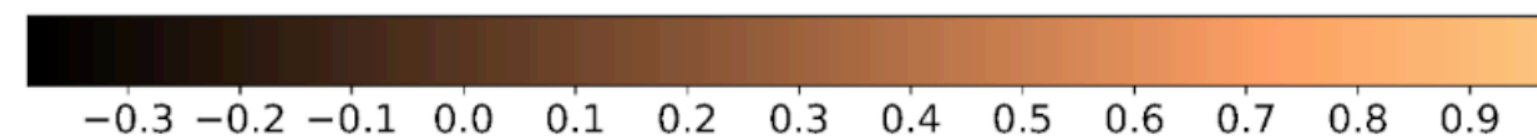

Conformational restraints Ligands

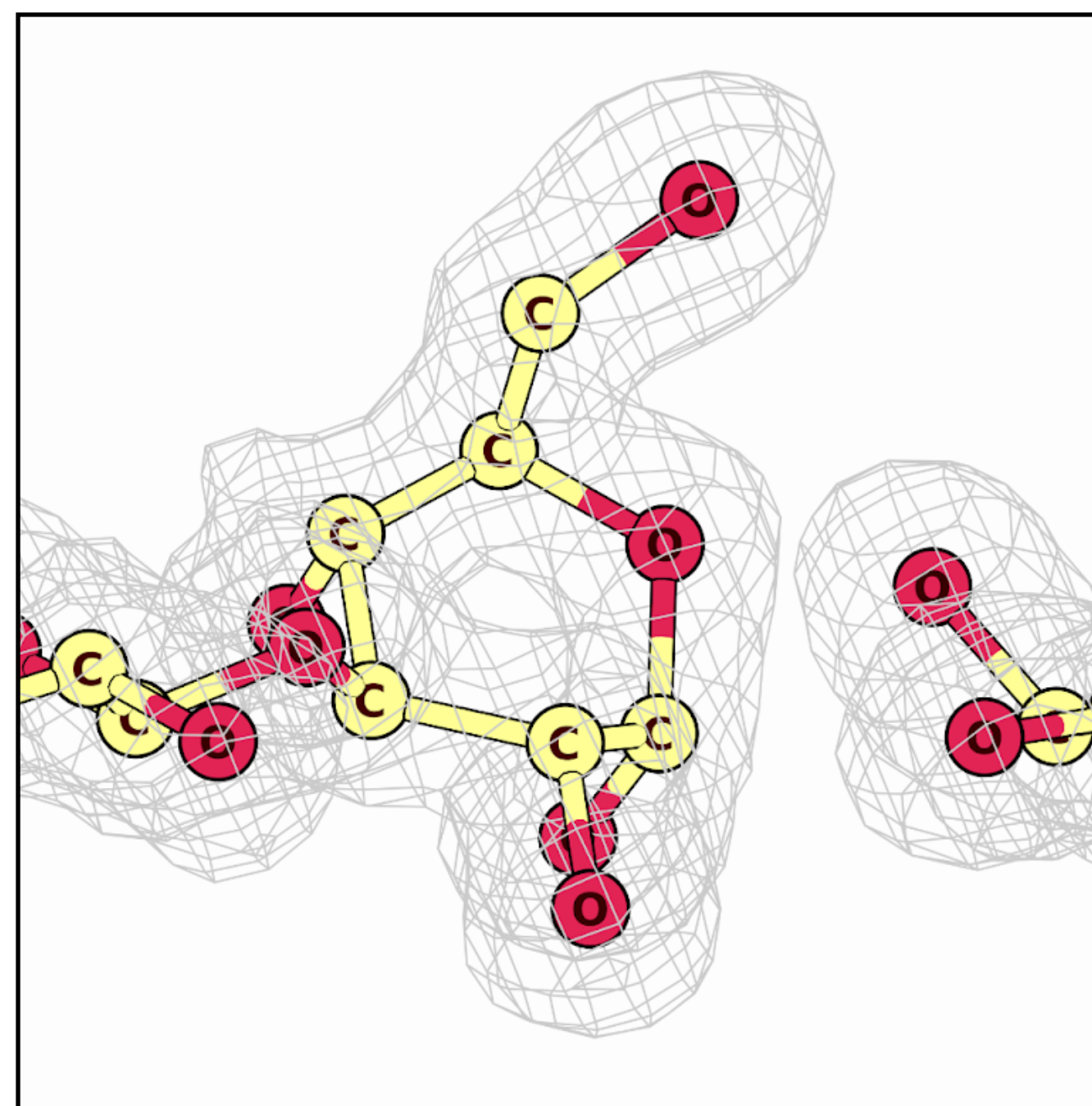

5UPM (GLC-C-1) in 2H_1
1.70 Å resolution, RSCC=0.96

Atanasova, Joosten, Nicholls & Agirre, 2022,
Acta Crystallographica D(78):455-465

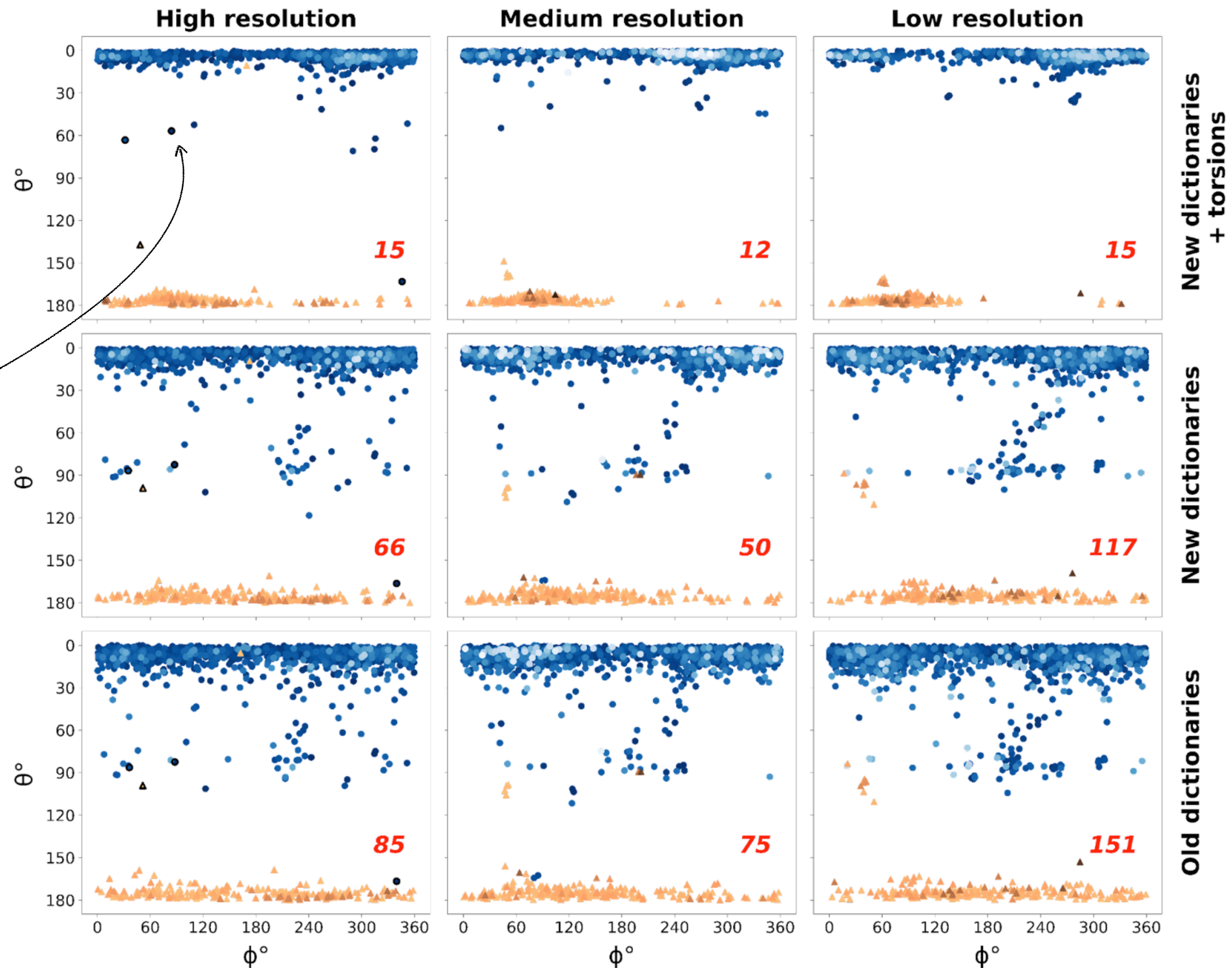

• D-sugars
 ▲ L-sugars

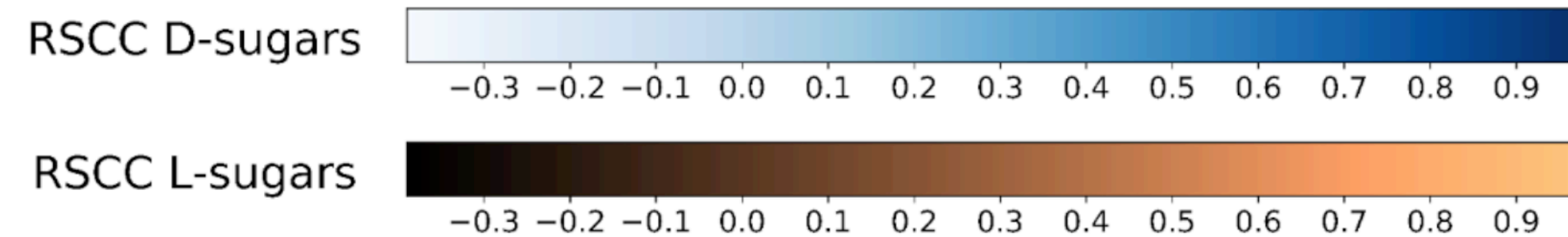

New dictionaries with conformational restraints

Reduction in R_{gap} = less overfitting

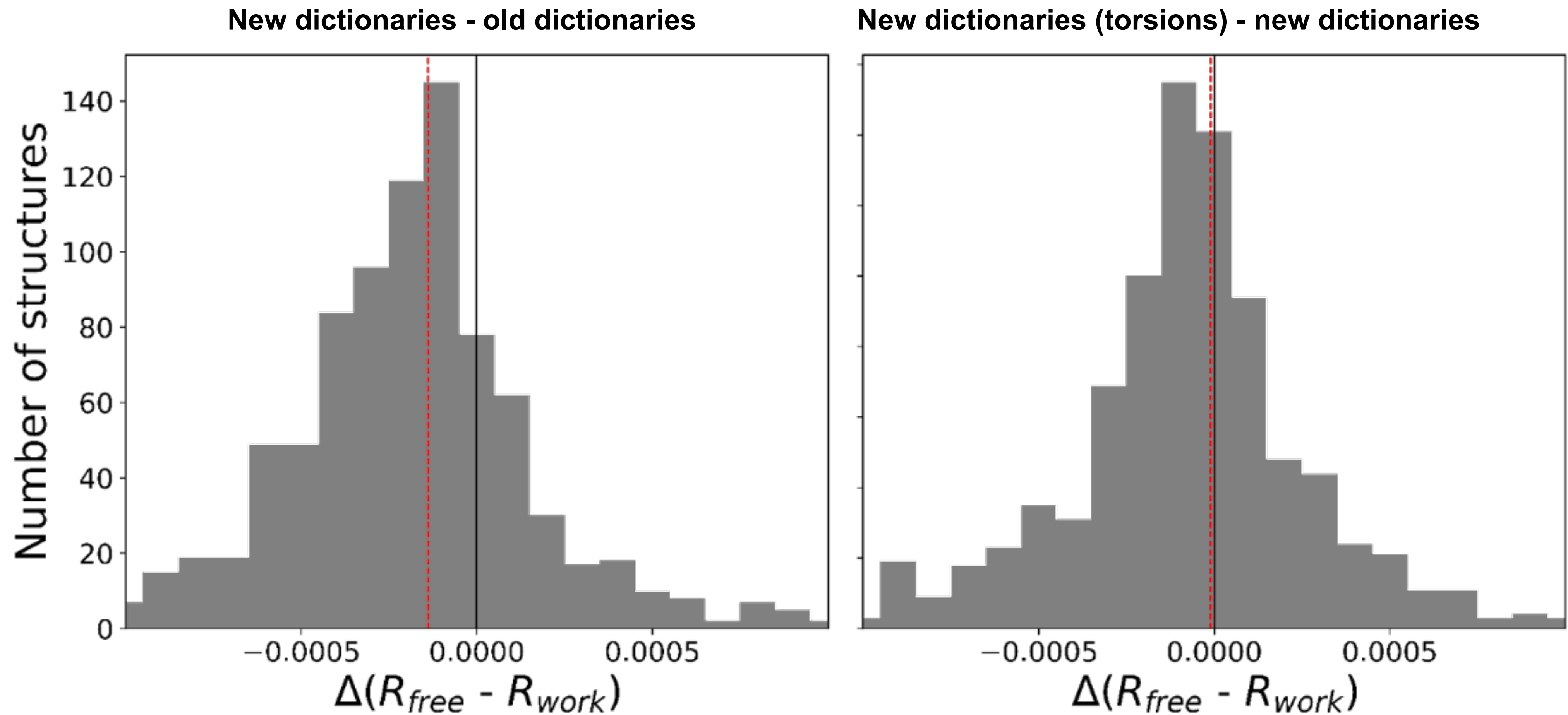

Improving restraint consistency across software: getting in touch with developers

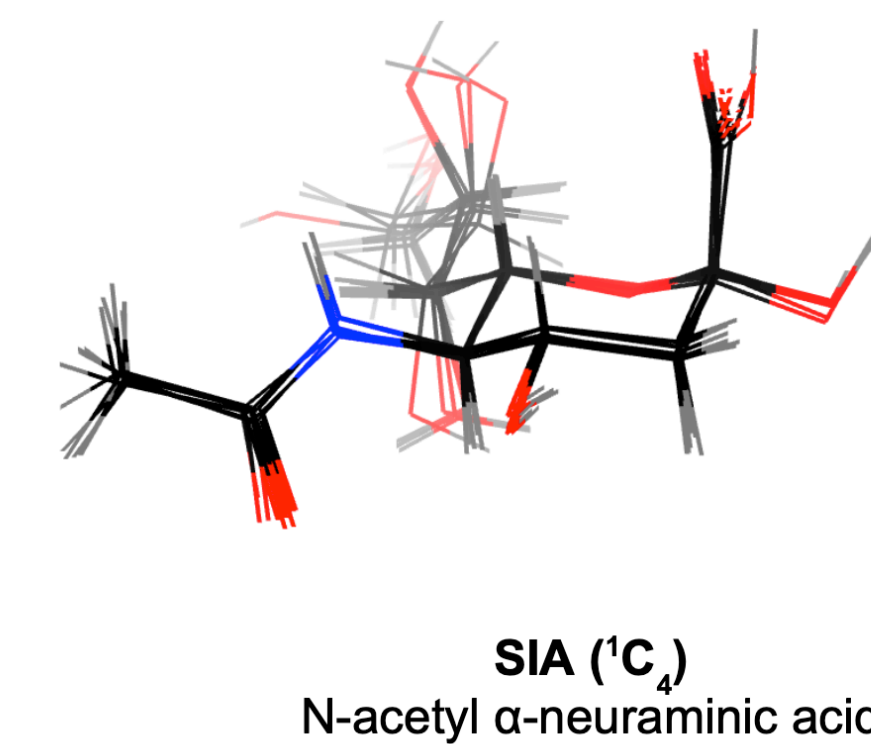
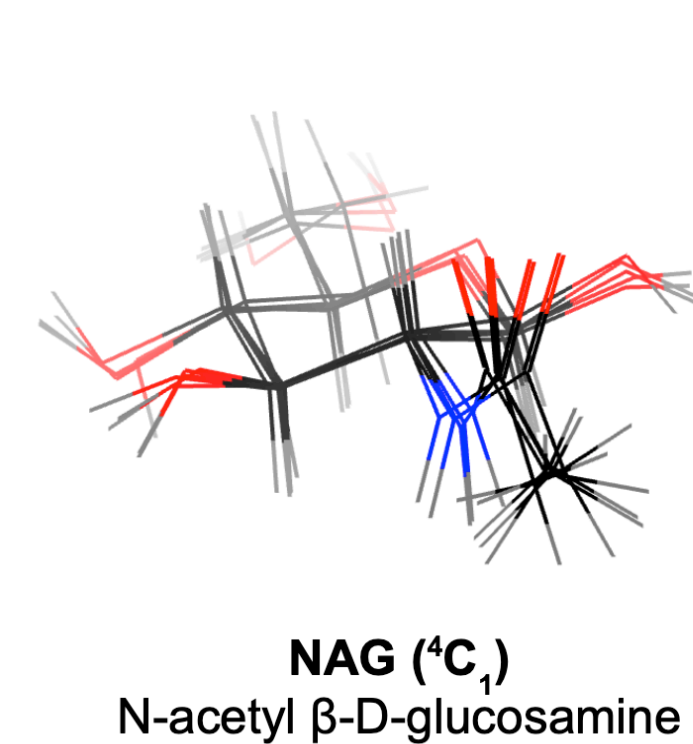
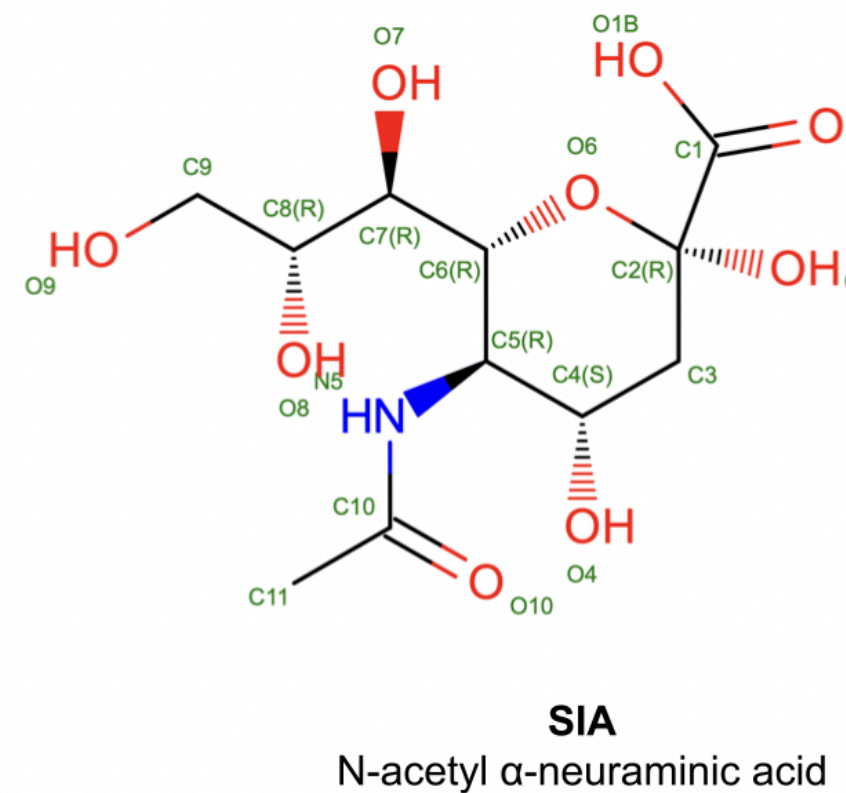
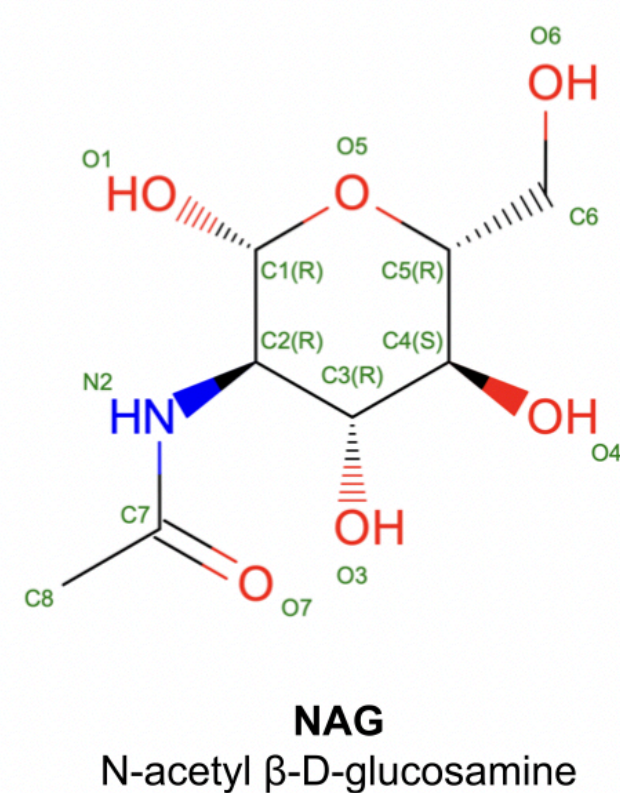
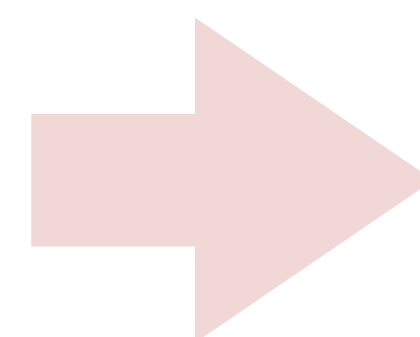
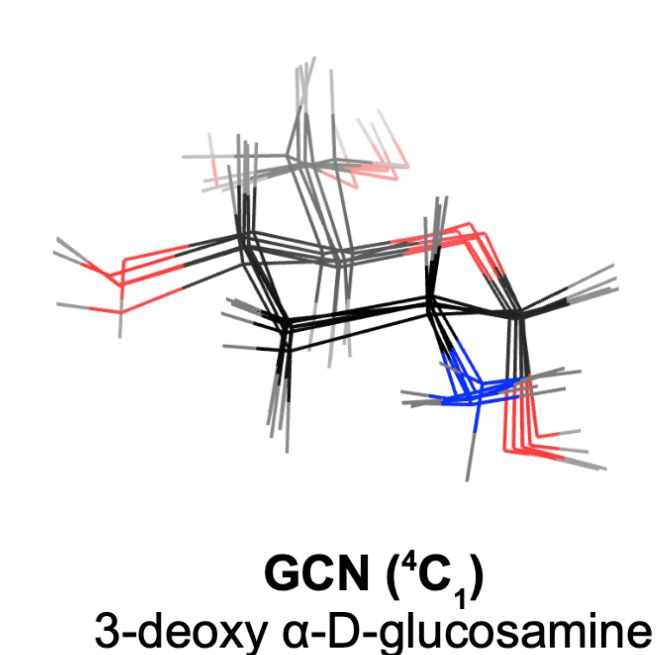
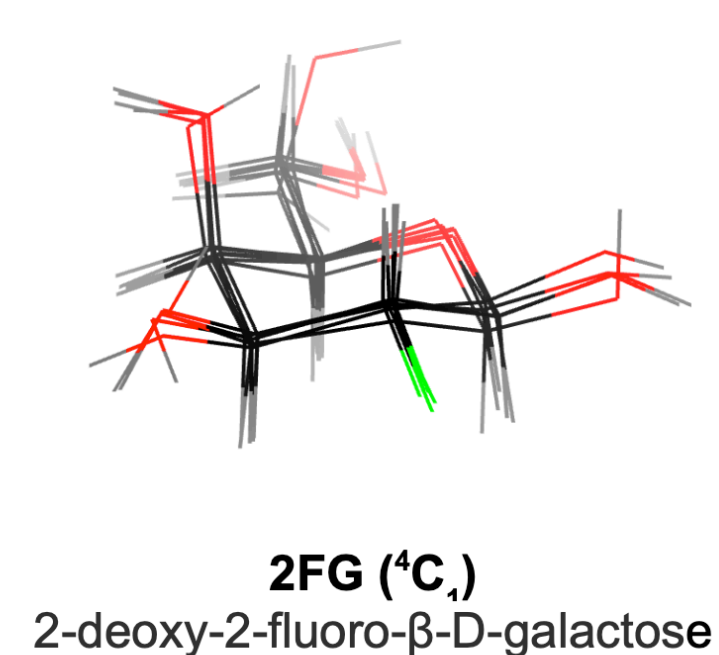
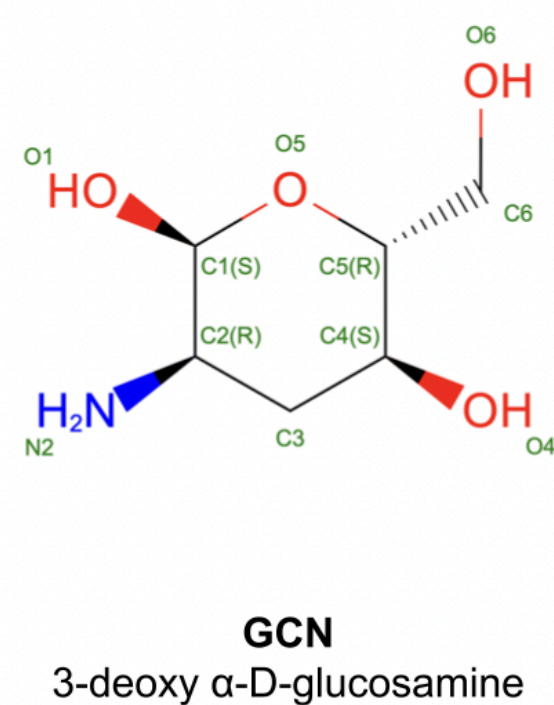
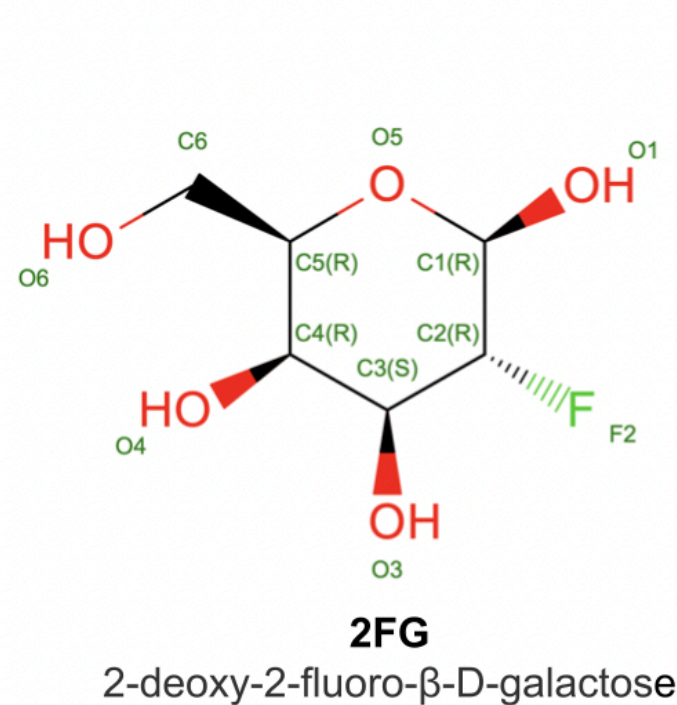
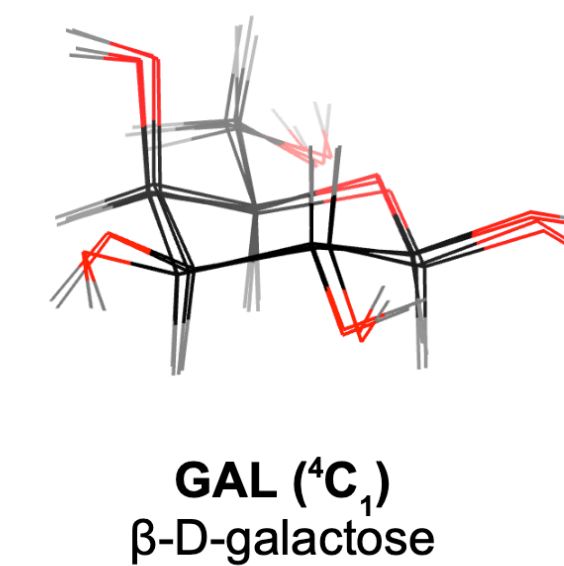
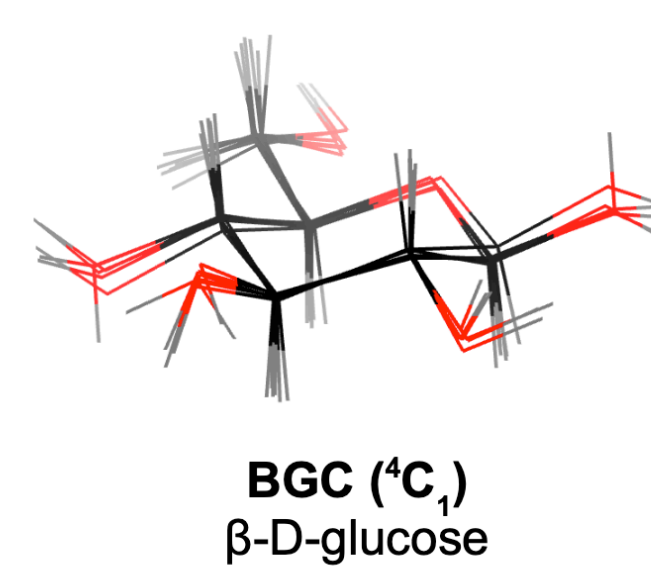
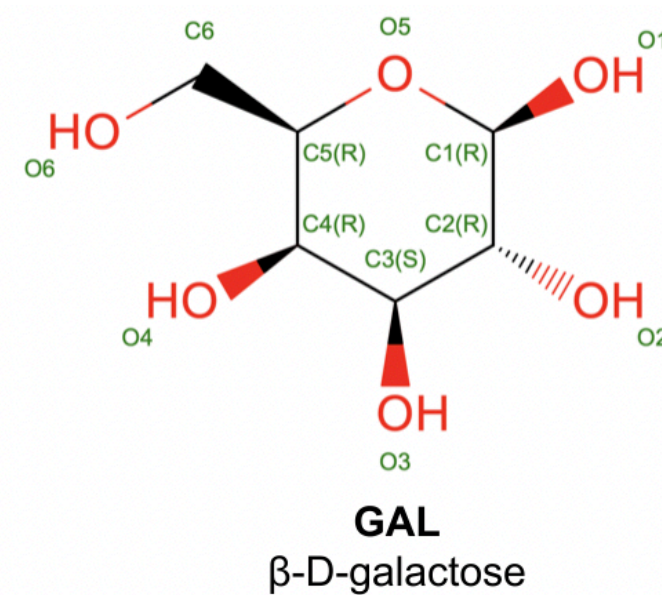
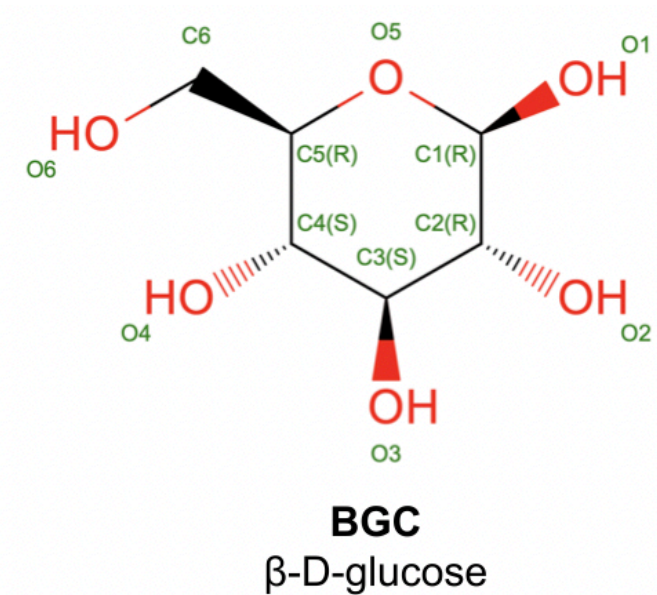

Restraints for C-mannosylation (MKV)

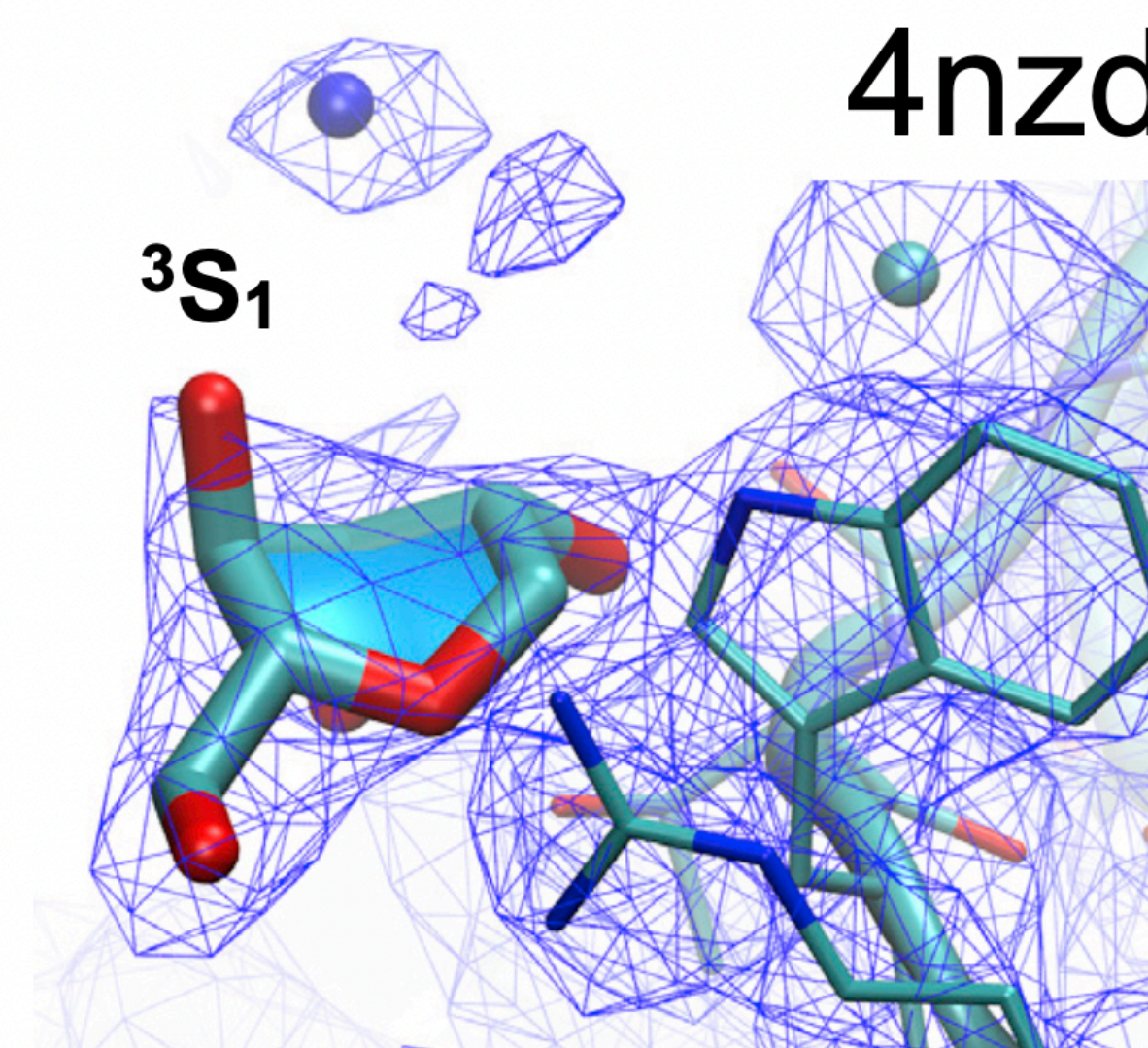
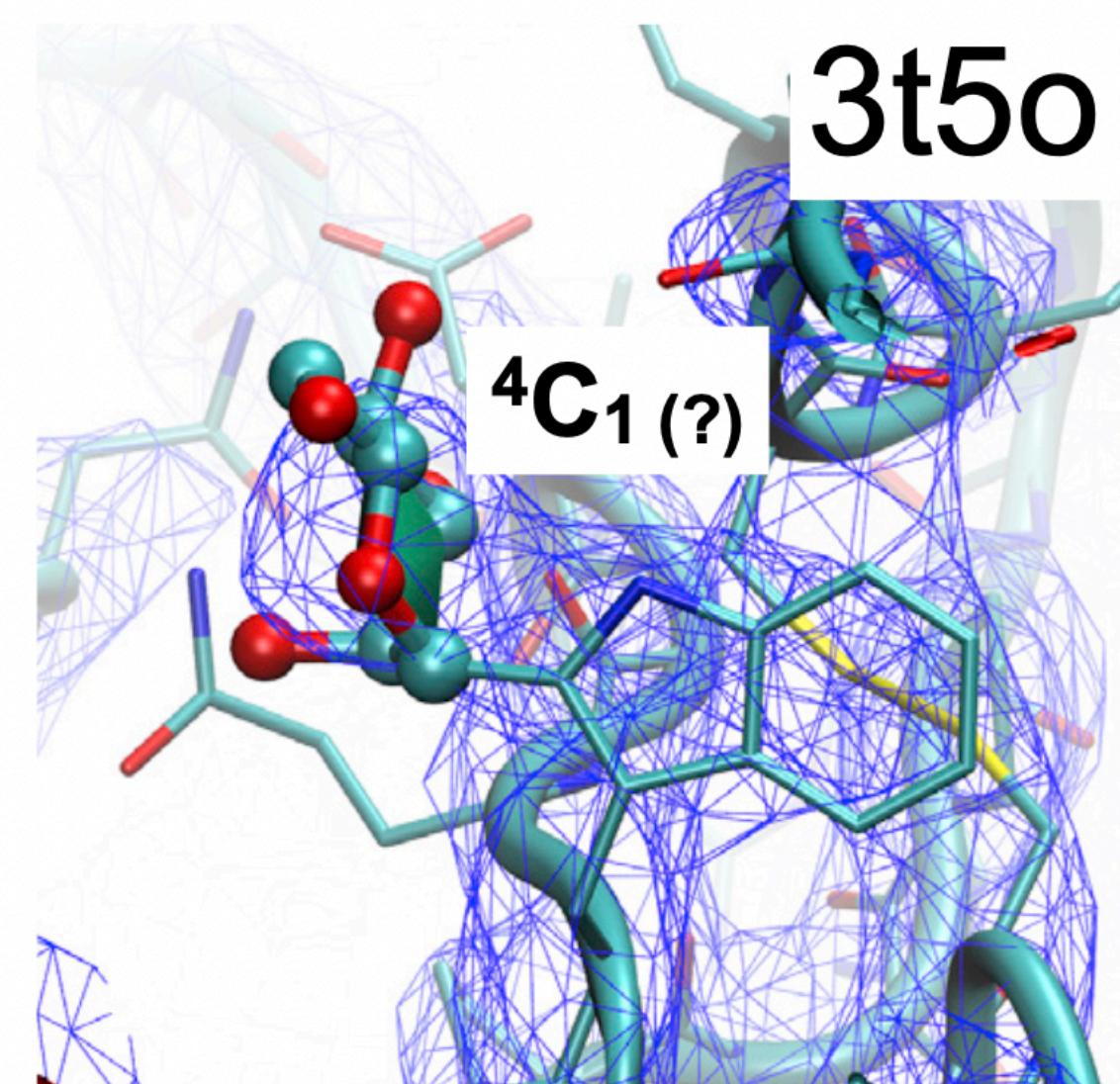
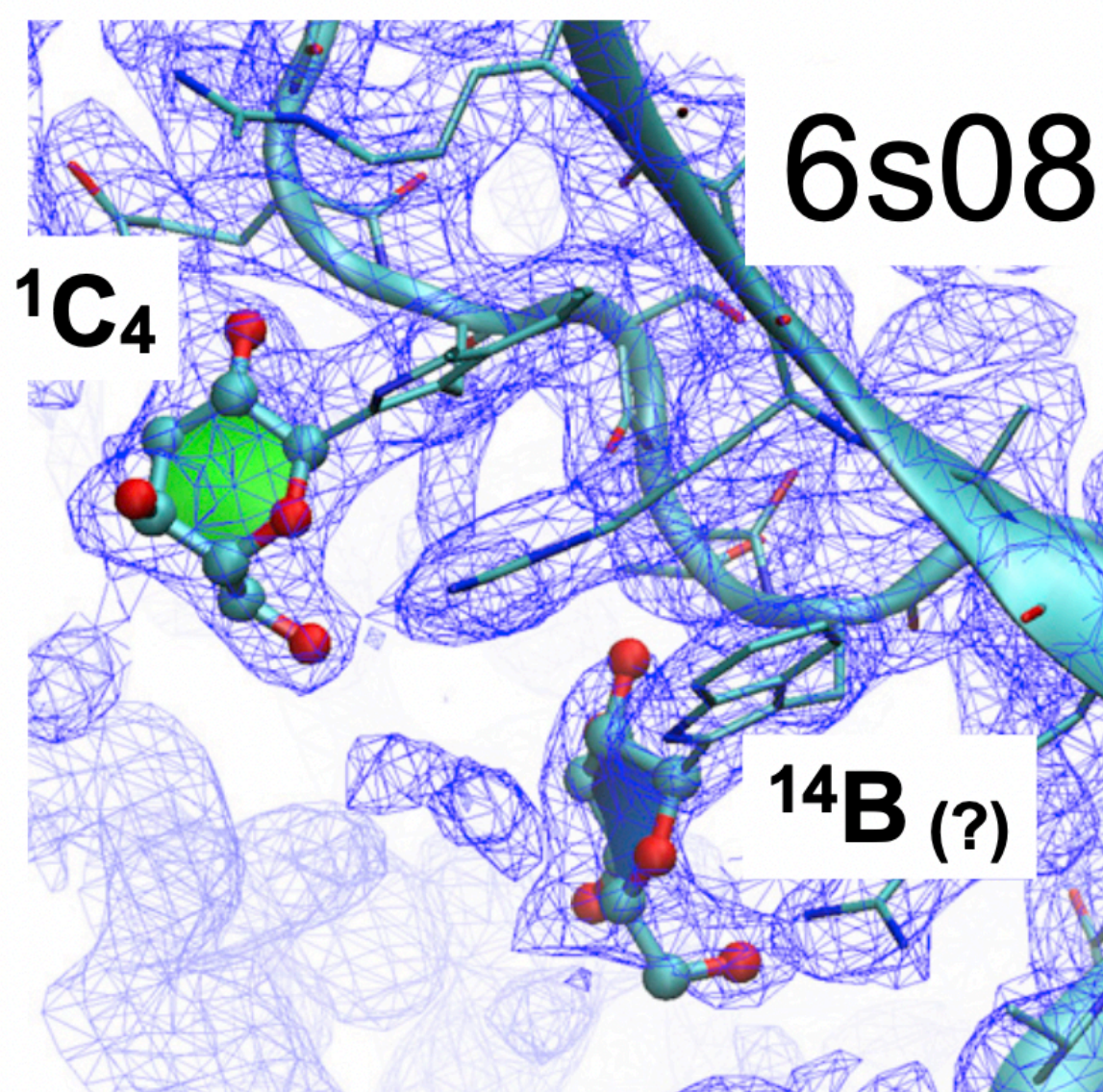
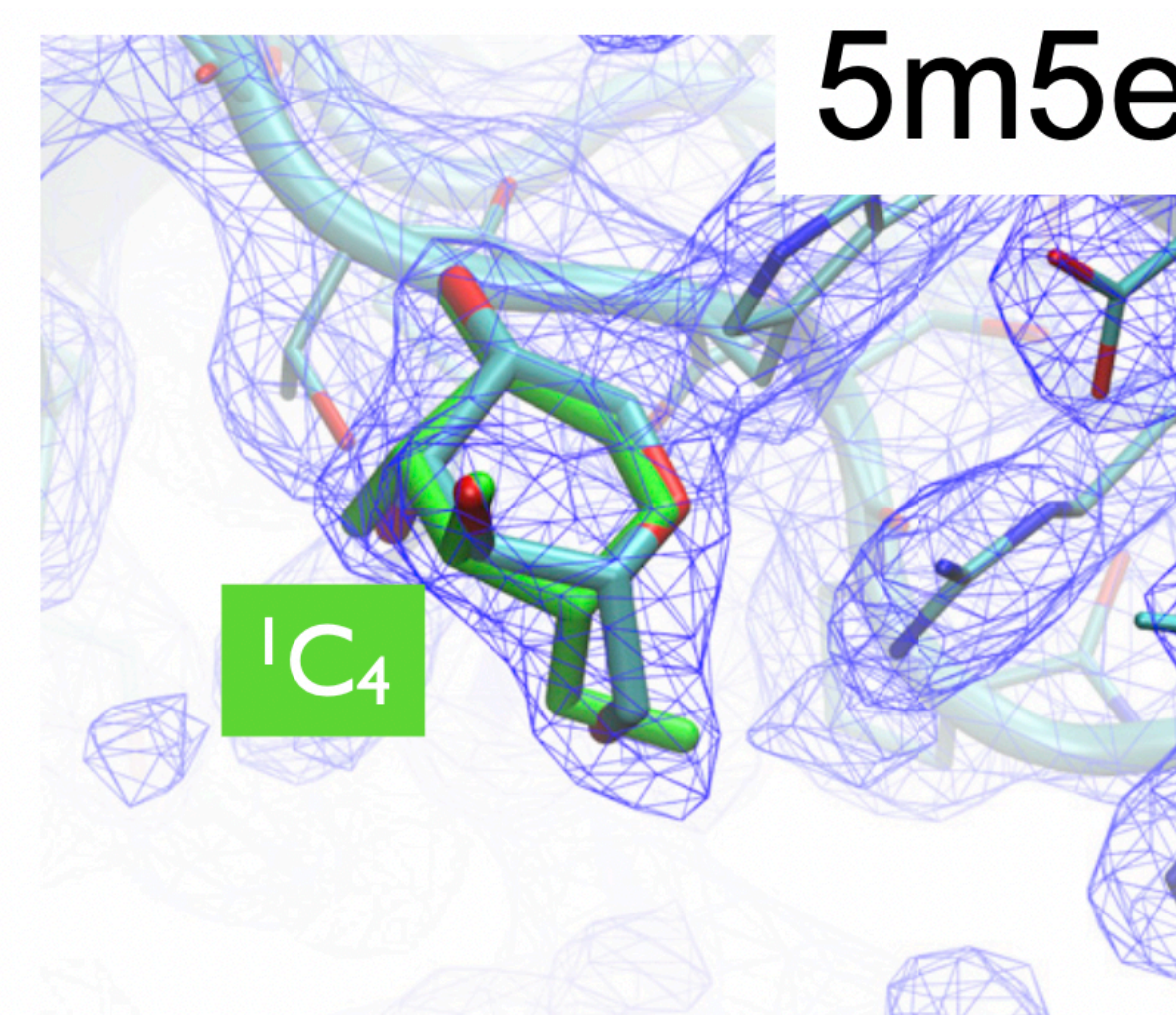
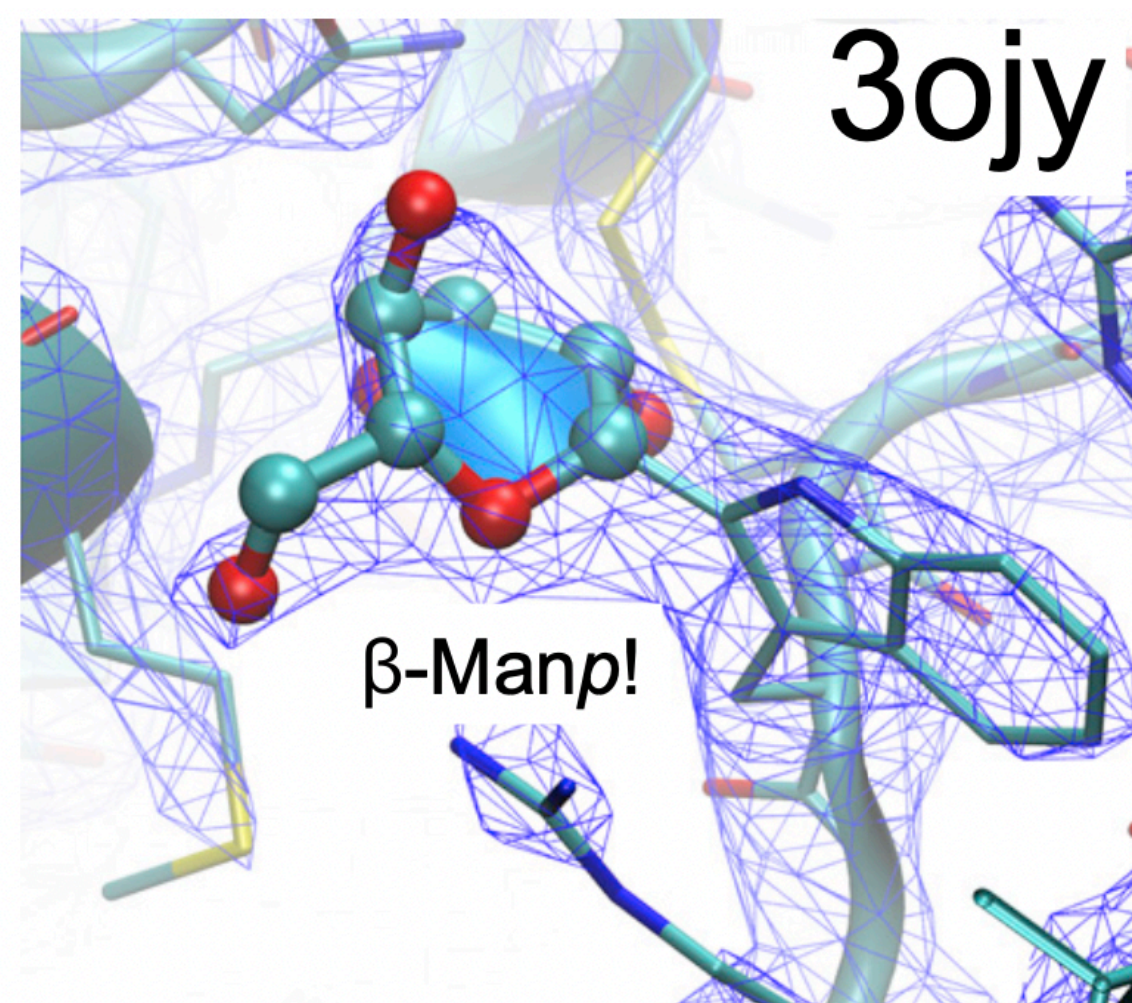
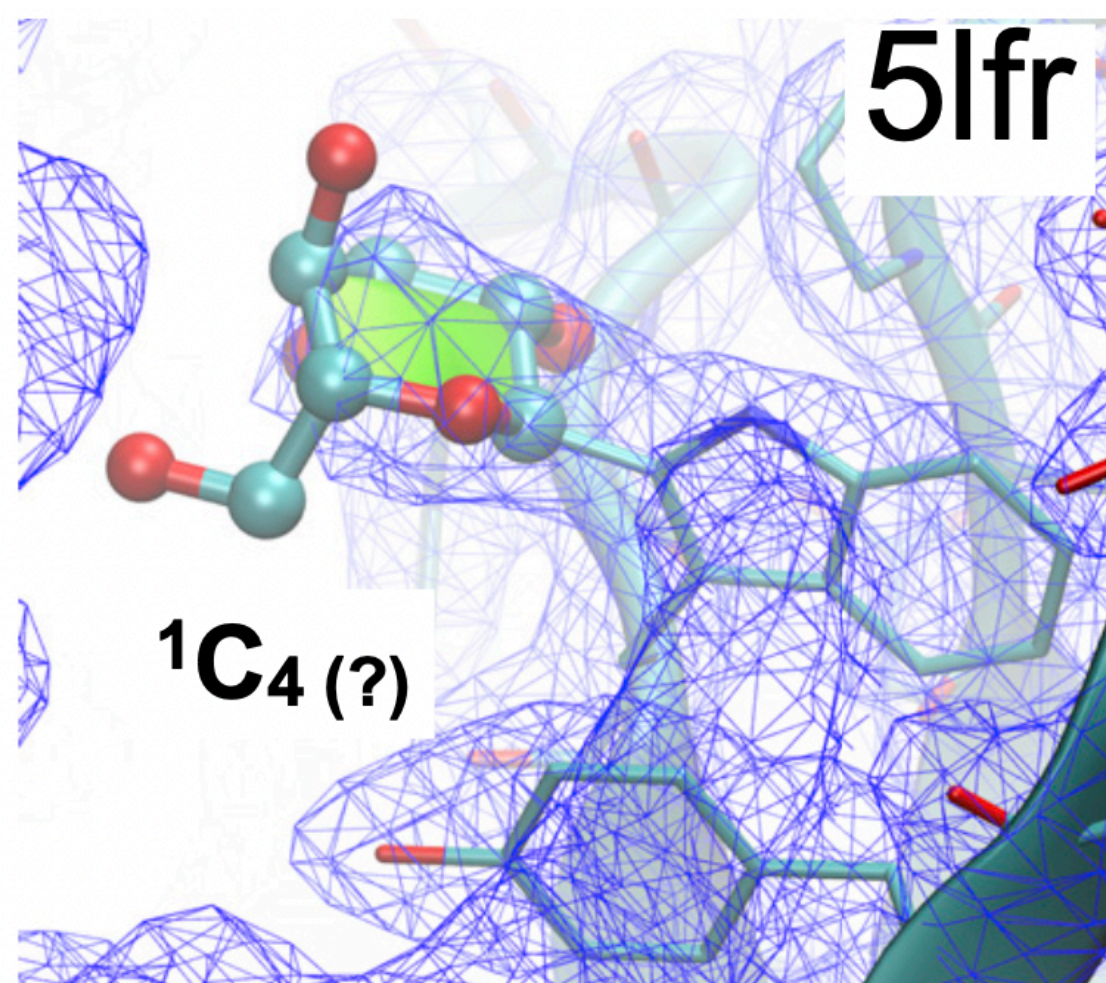

Restraints for C-mannosylation (MKV)

4C_1 chair, beta link?
Enzyme makes an alpha link...

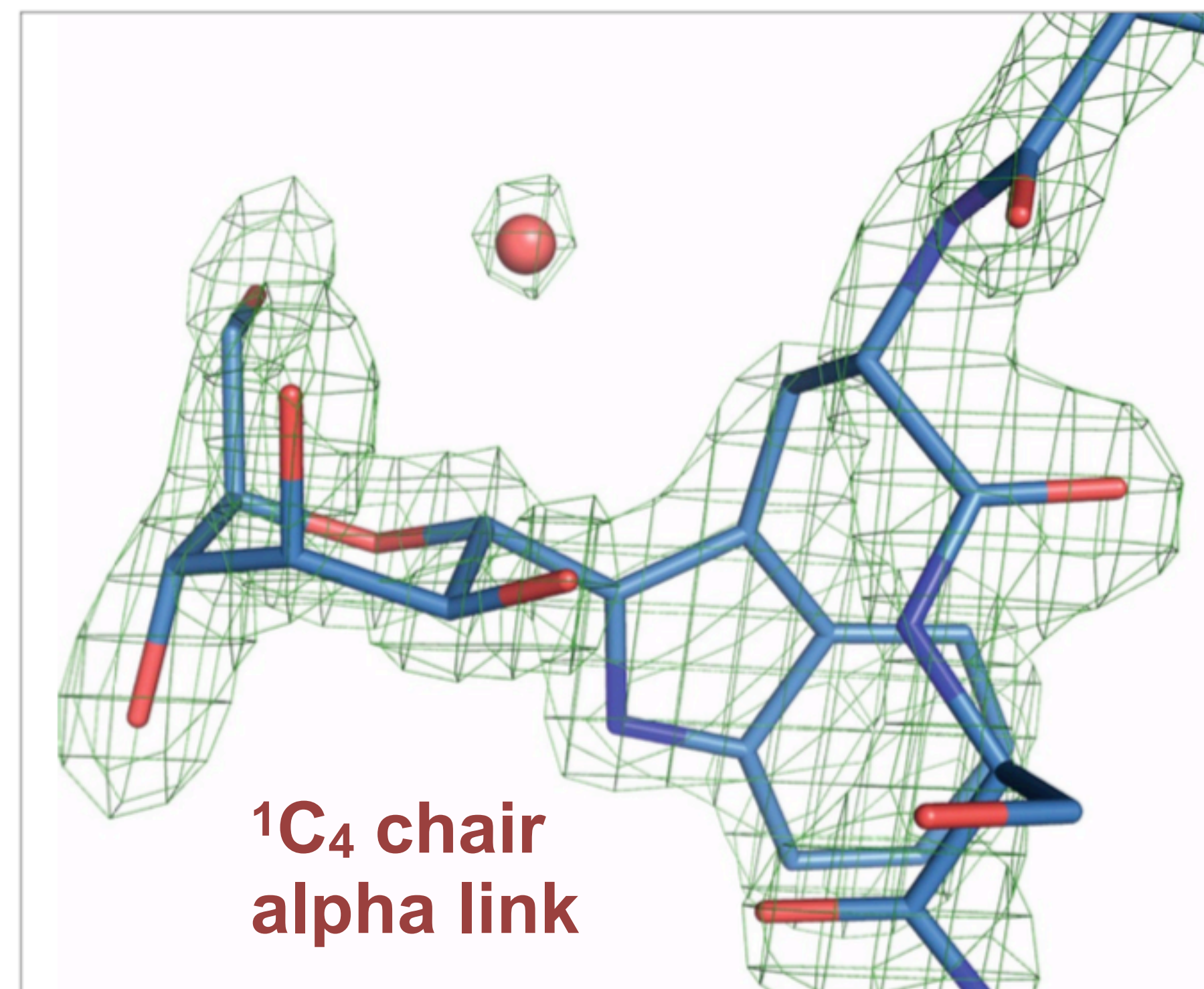
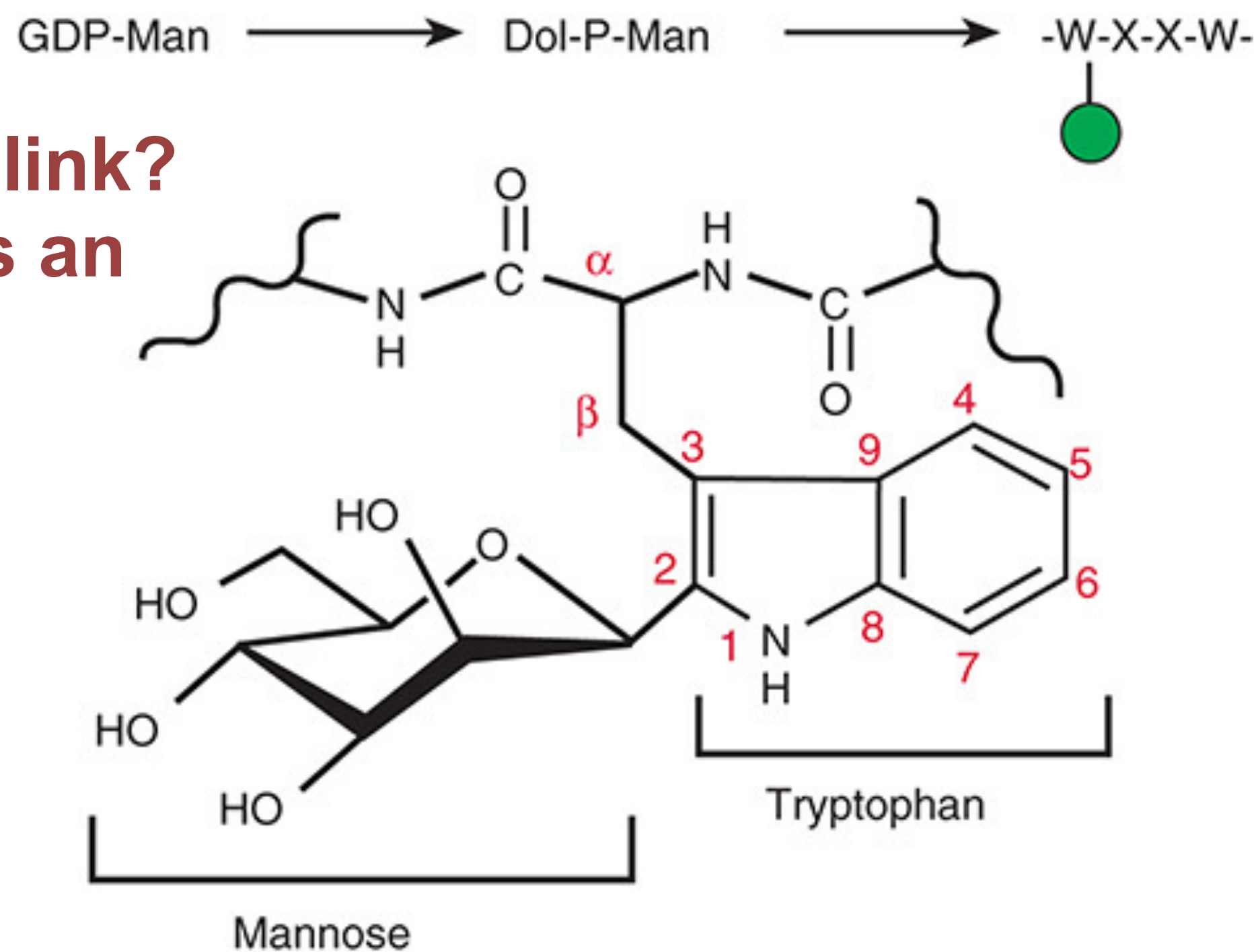
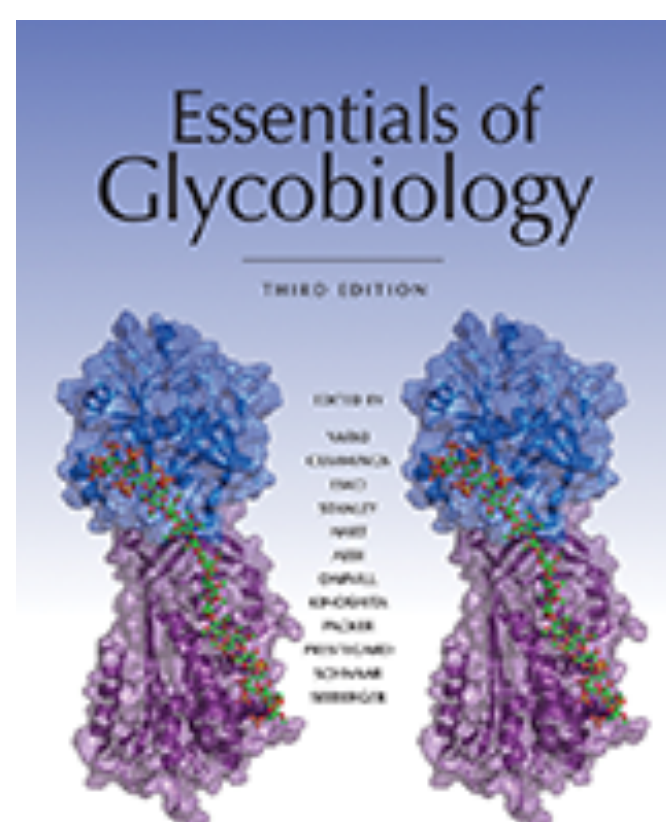

Essentials of Glycobiology [Internet]. 3rd edition.
Varki A, Cummings RD, Esko JD, et al., editors.
Cold Spring Harbor (NY): Cold Spring Harbor Laboratory Press; 2015-2017.

PDB 6PLH, omit mFo-DFc map at 1.5σ , 1.6 \AA data
John, Jarva, Shah, Mao, Chappaz, Birkinshaw, Czabotar, Lo, Scott & Goddard-Borger, 2021, Nature Chemical Biology 17: 428-437

Restraints for C-mannosylation (MKV)

**¹C₄ chair
alpha link**

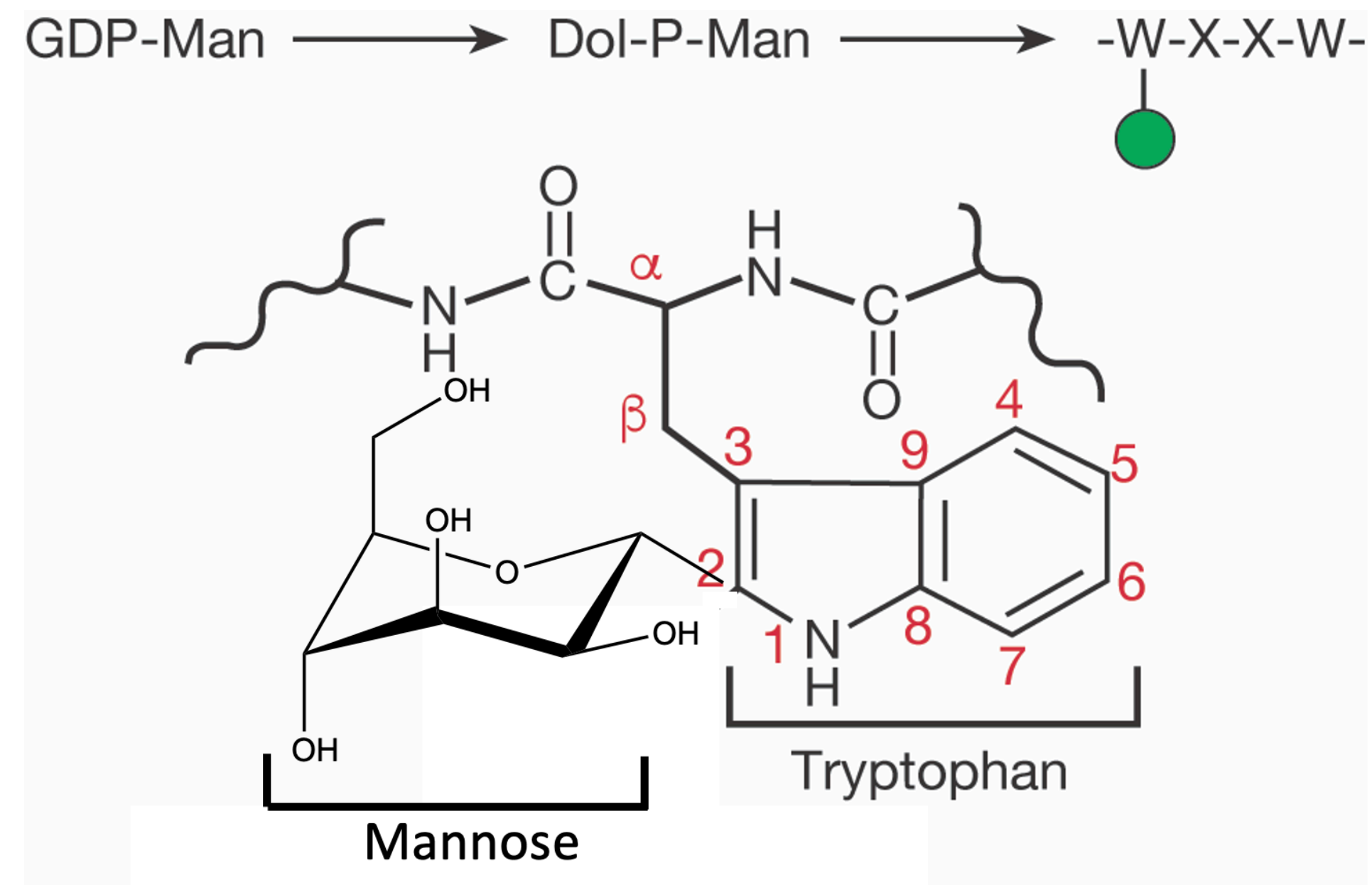
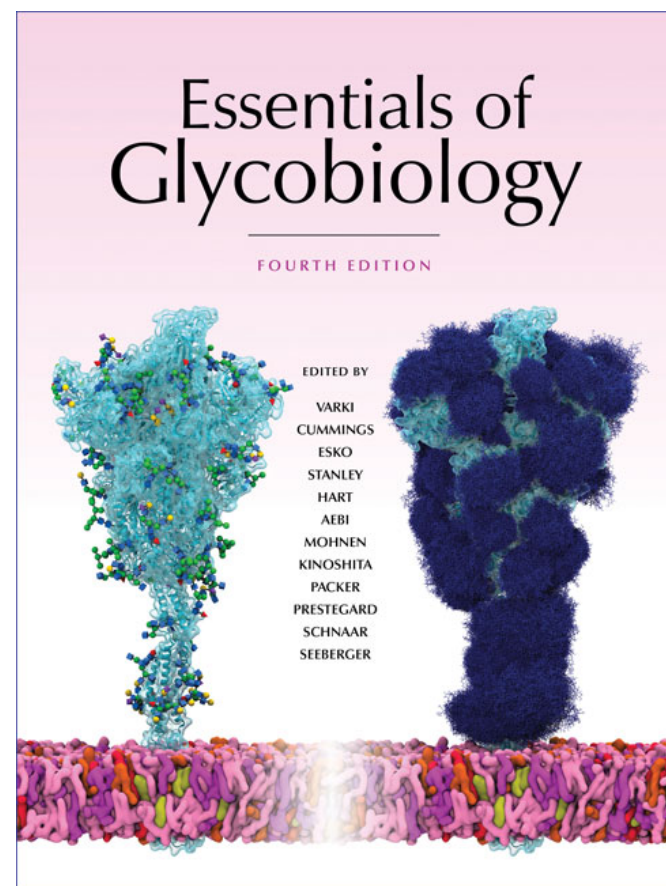

Updated figure courtesy of Prof. Pamela Stanley (Einstein College, USA)

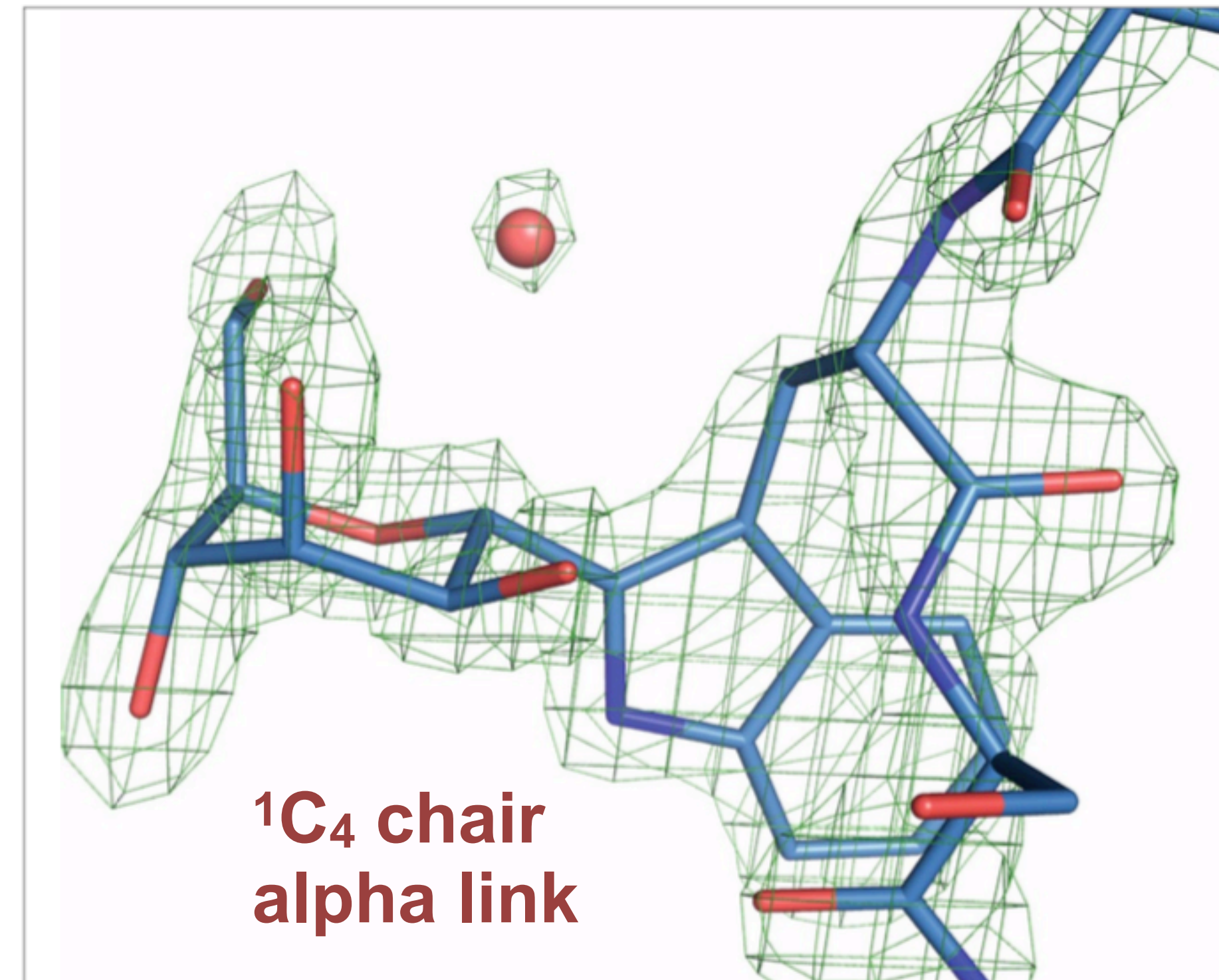

PDB 6PLH, omit mFo-DFc map at 1.5 σ , 1.6 Å data

John, Jarva, Shah, Mao, Chappaz, Birkinshaw, Czabotar, Lo, Scott & Goddard-Borger, 2021,
Nature Chemical Biology 17: 428-437

Essentials of Glycobiology [Internet]. 4th edition.
Varki A, Cummings RD, Esko JD, et al., editors.
Cold Spring Harbor (NY): Cold Spring Harbor Laboratory Press; 2022.

Restraints for C-mannosylation (MKV)

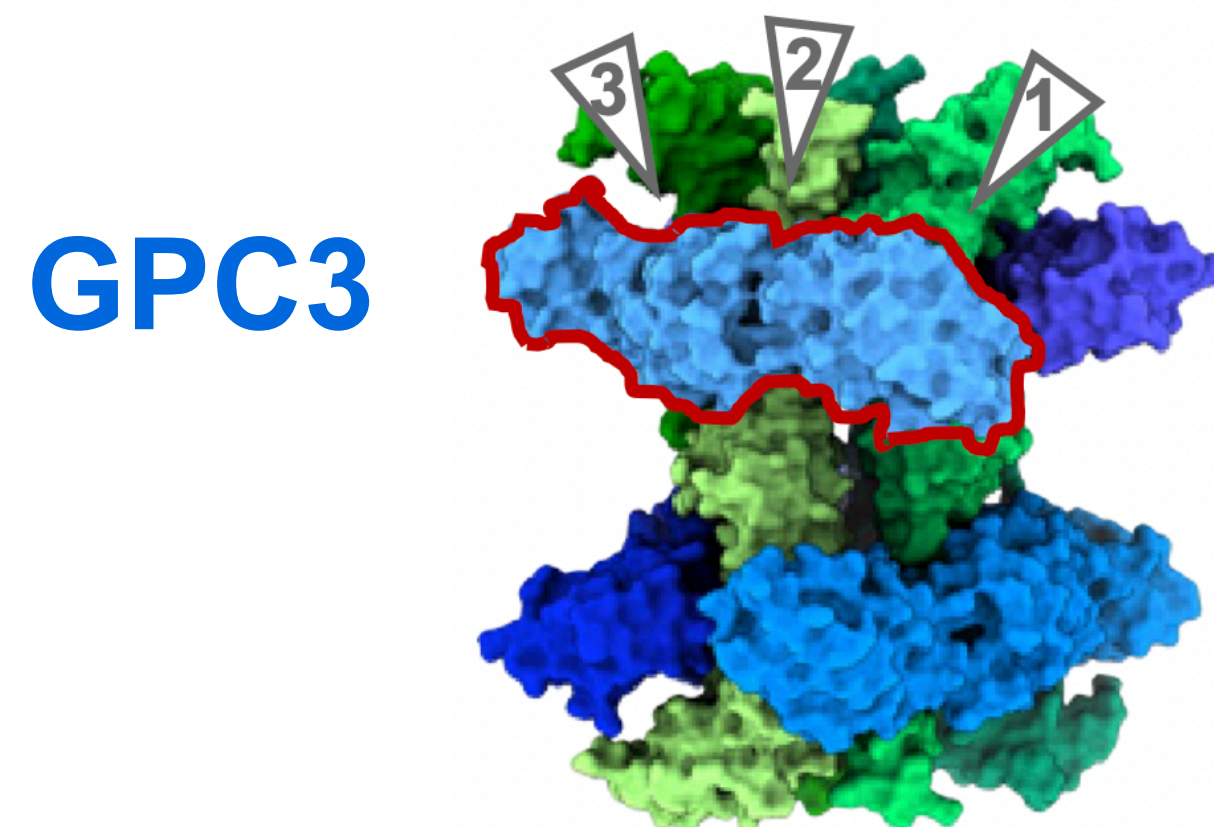
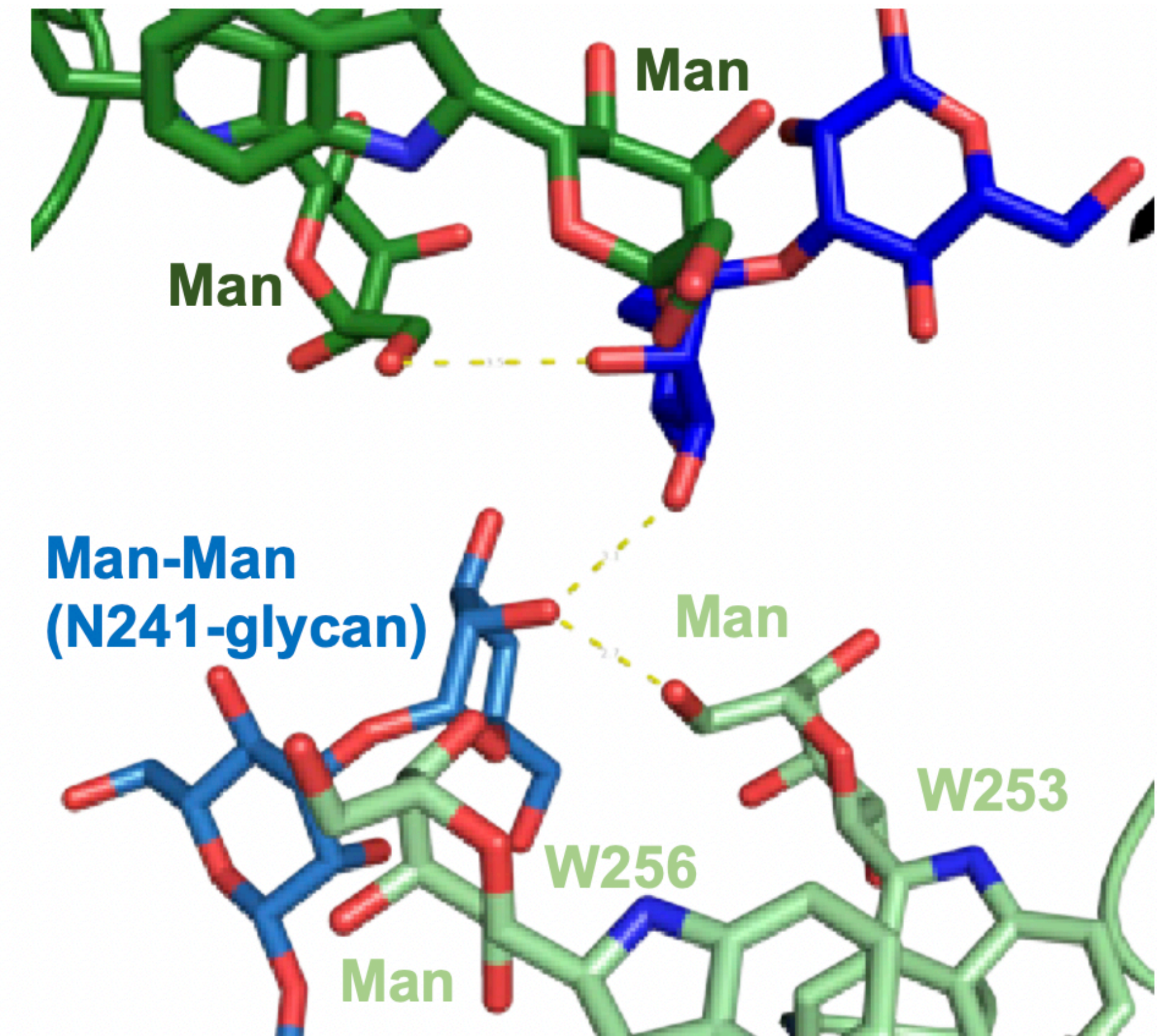
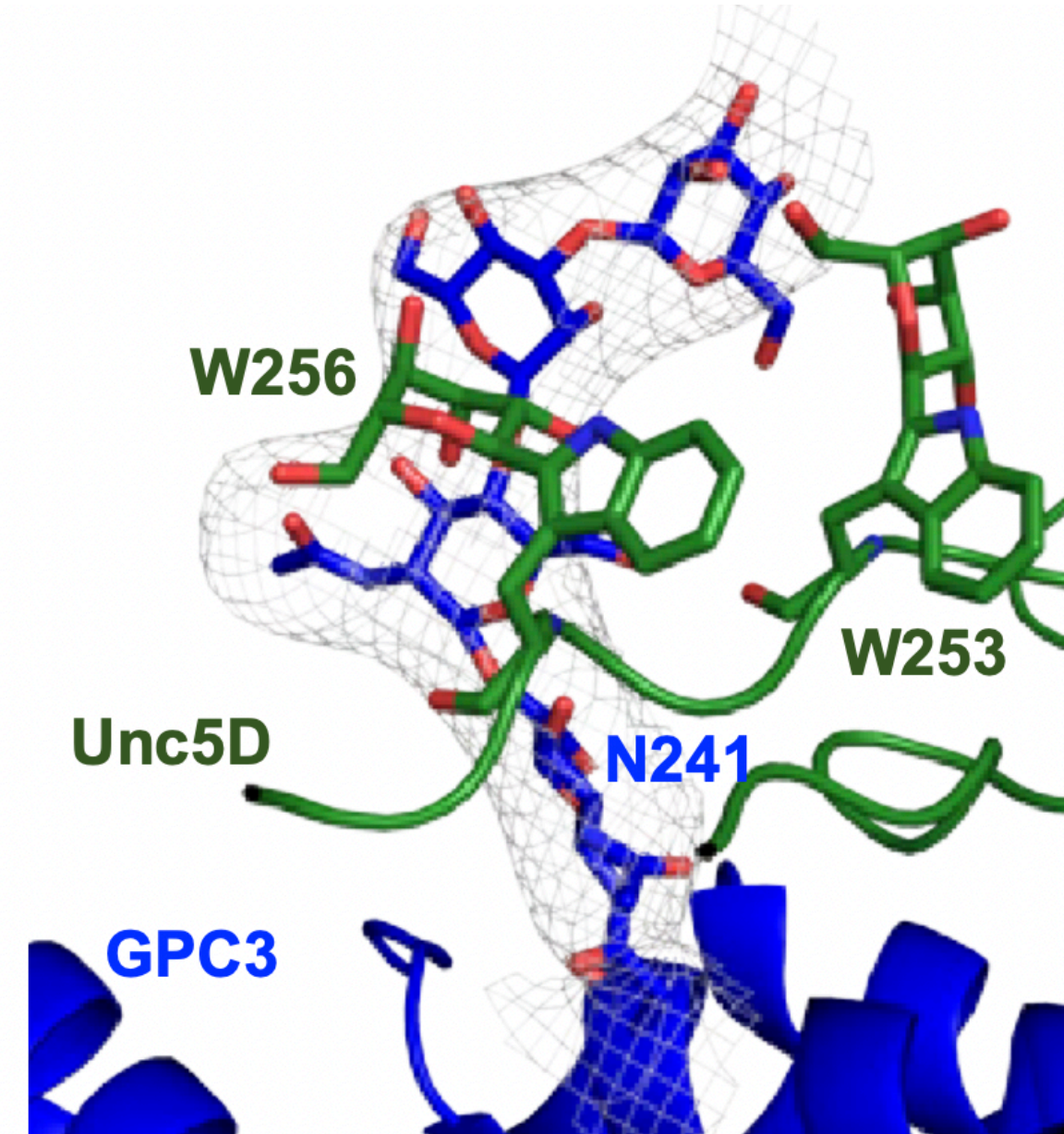
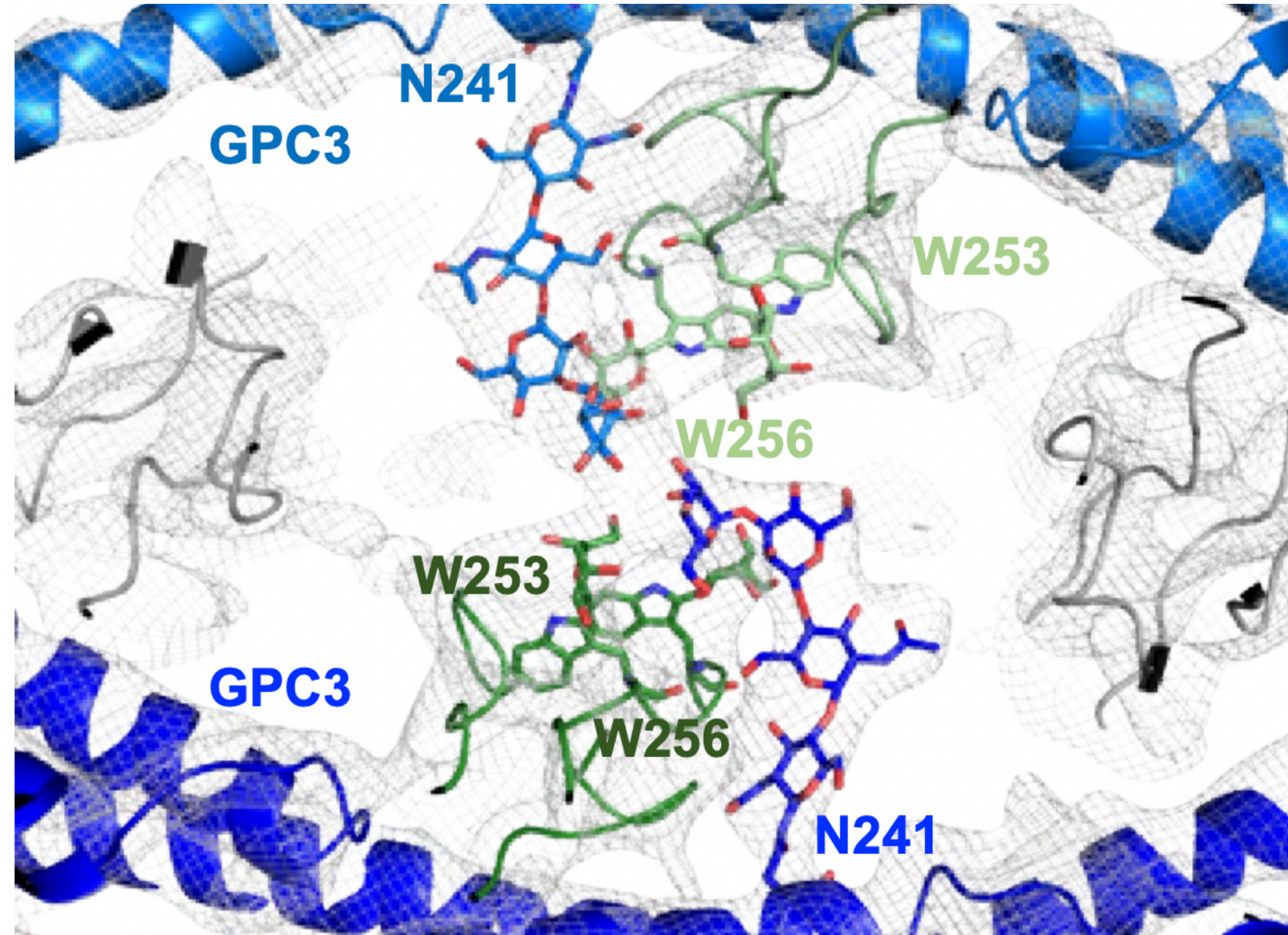

Unc5D

Akkermans, Delloye-Bourgeois, Peregrina, Carrasquero, Kokolaki, Santana, Chavent, Reynaud, Raj, Agirre, Aksu, White, Lowe, Ben Amar, Zaballa, Huo, McCubbin, Comoletti, Owens, Robinson, Castellani, del Toro & Seiradake, 2022, Cell 185(21): 3931-3949.

New Support for C-mannosylation

- **Next version of Privateer will (already available in Web App)**
 - checks that mannopyranose ring is 1C_4
 - makes sure linkage is alpha, shouts if it isn't
- For refinement at **low resolution with servalcat, next version of Privateer will**
 - External torsion restraints for link and 1C_4 conformation
 - Creates modified linkage dictionary to impose torsions for 1C_4 conformation on the mannose

Analysis of linkage torsions (MKV)

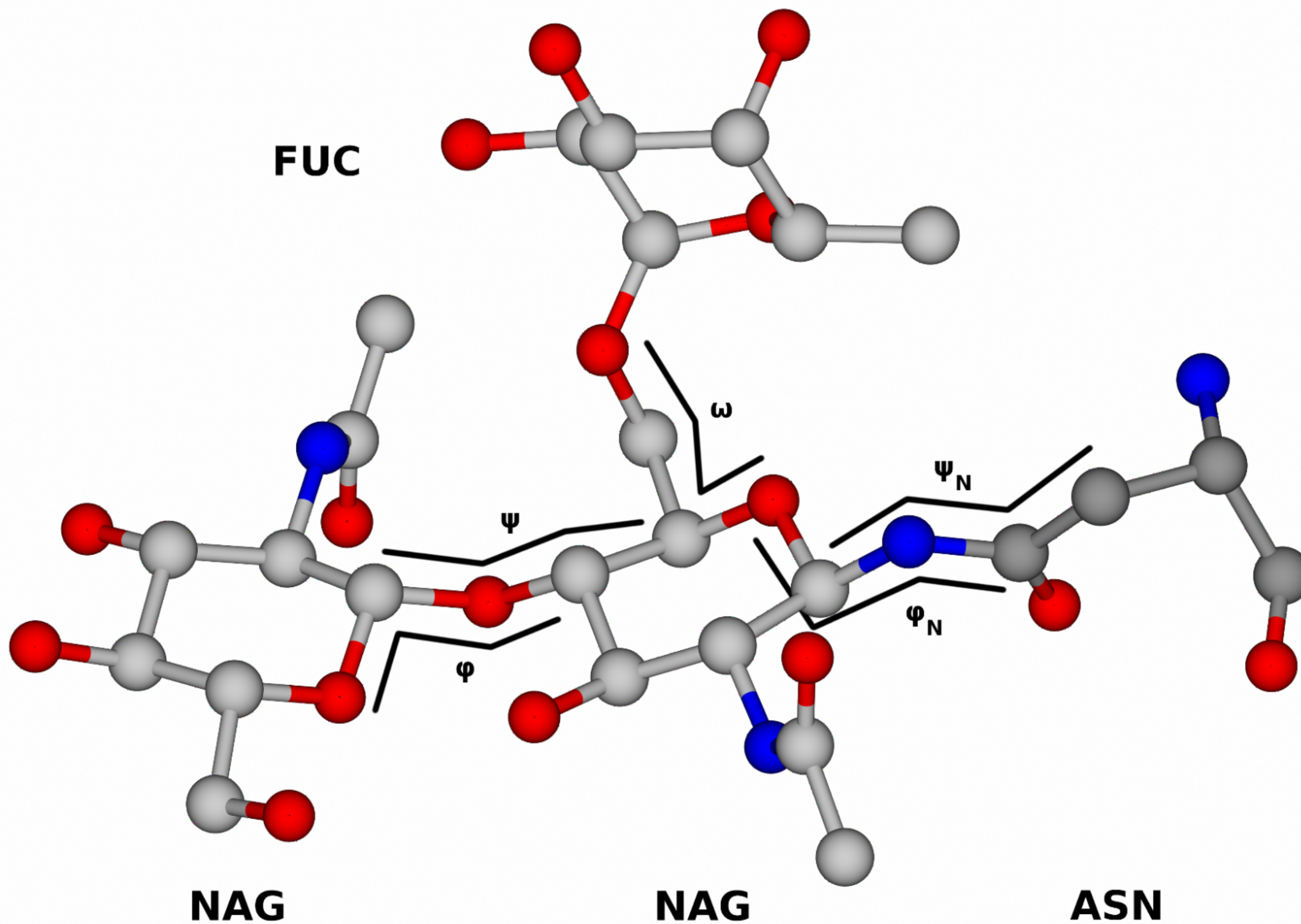
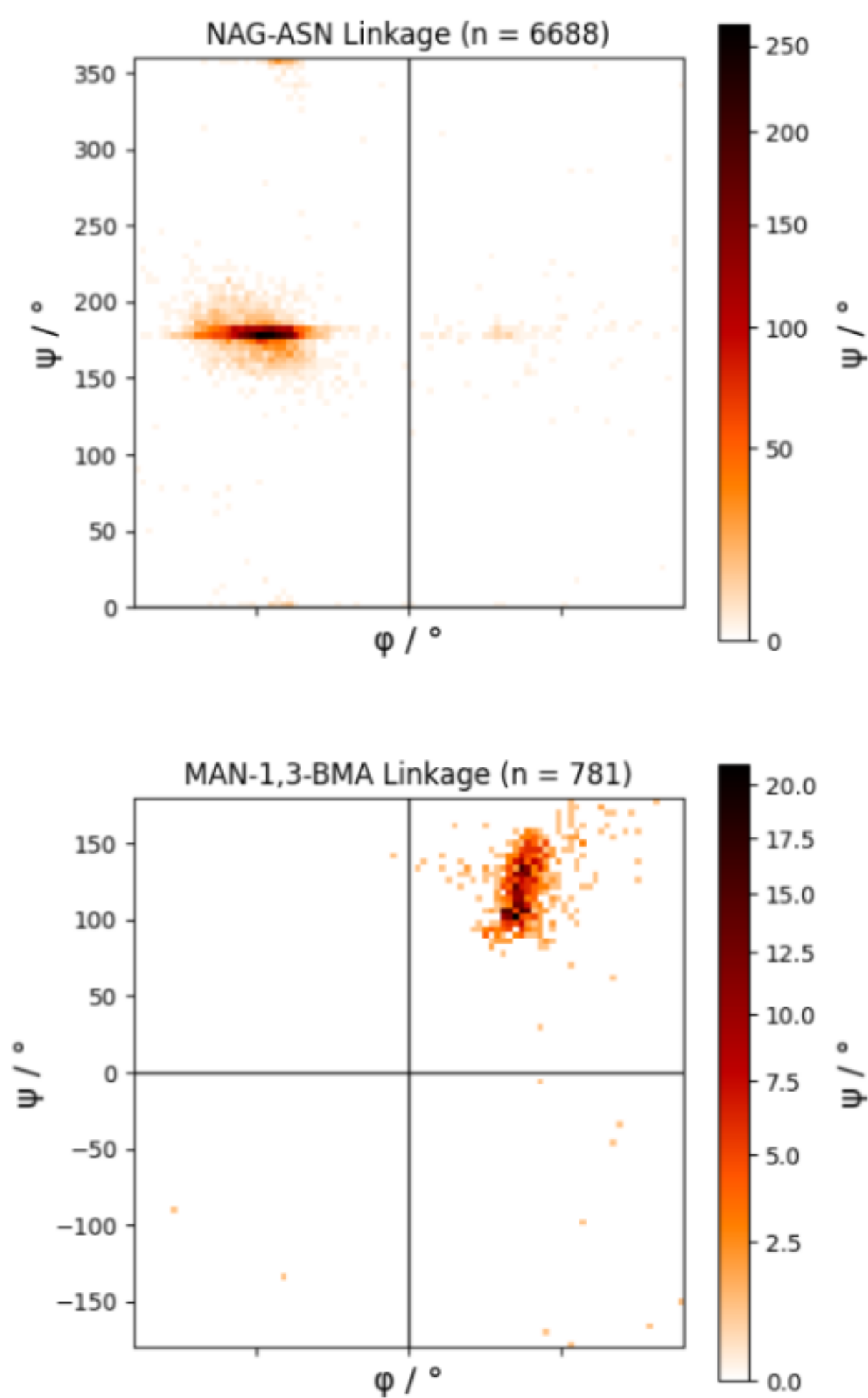

Dialpuri, J. S., Bagdonas, H., Atanasova, M., Schofield, L. C., Hekkelman, M. L., Joosten, R. P. & Agirre, J., 2023. Analysis and validation of overall N-glycan conformation in Privateer. *Acta Crystallographica Section D*, 79, 462-472.

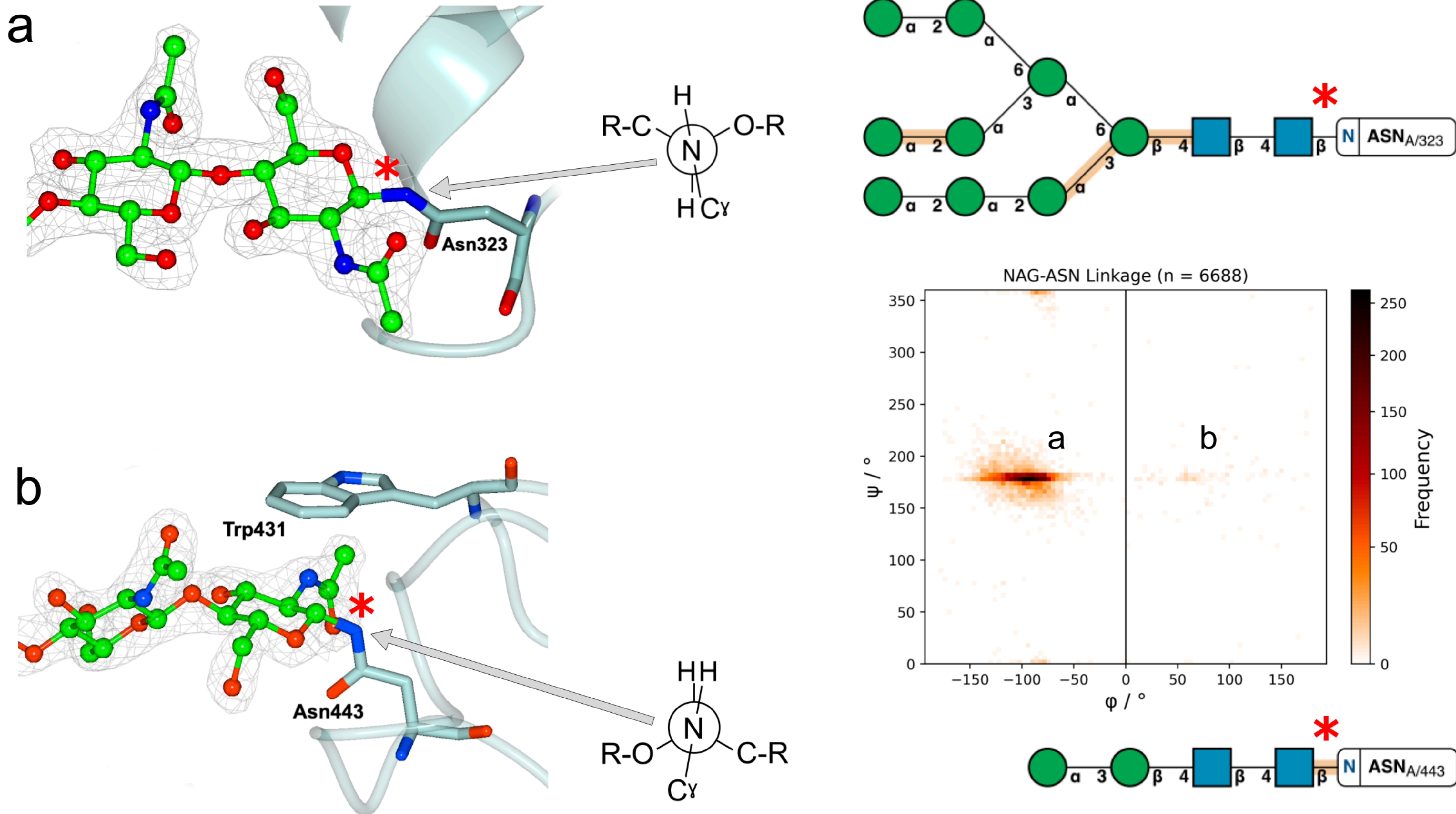

Dialpuri, J. S., Bagdonas, H., Atanasova, M., Schofield, L. C., Hekkelman, M. L., Joosten, R. P. & Agirre, J., 2023. Analysis and validation of overall N-glycan conformation in Privateer. *Acta Crystallographica Section D*, 79, 462-472.

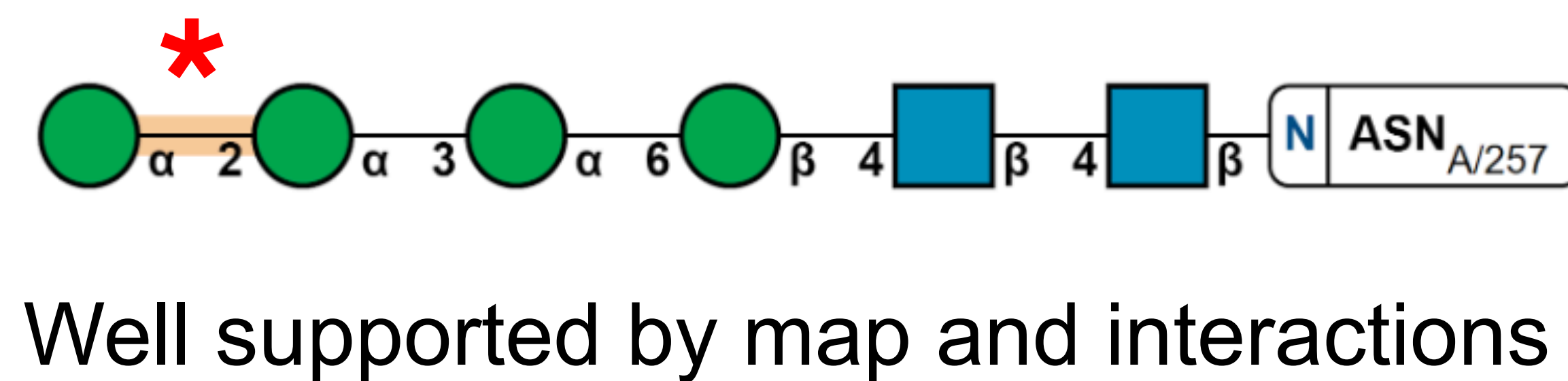
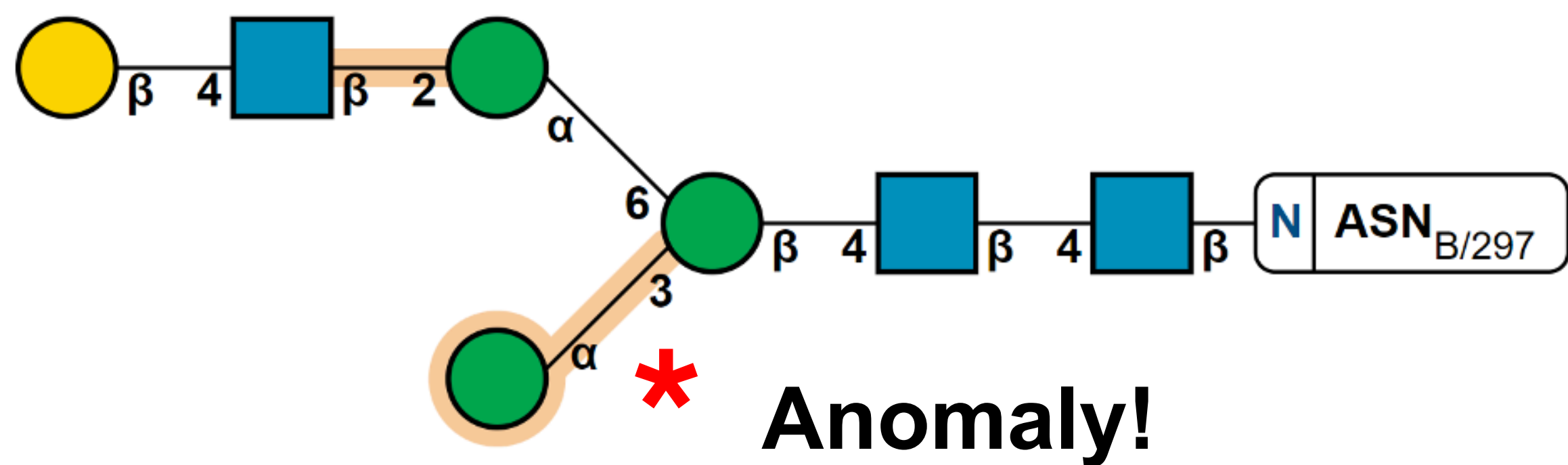
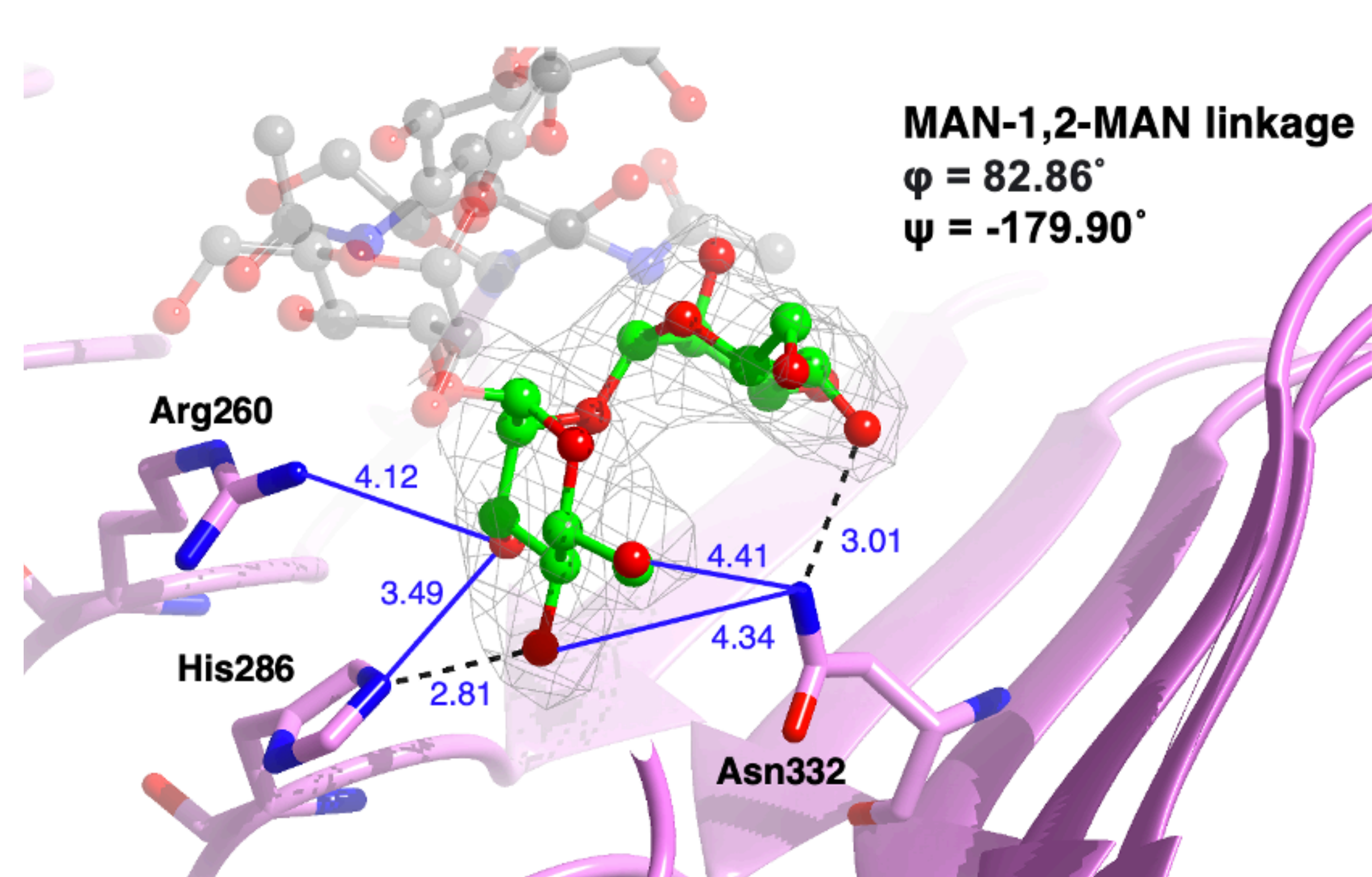
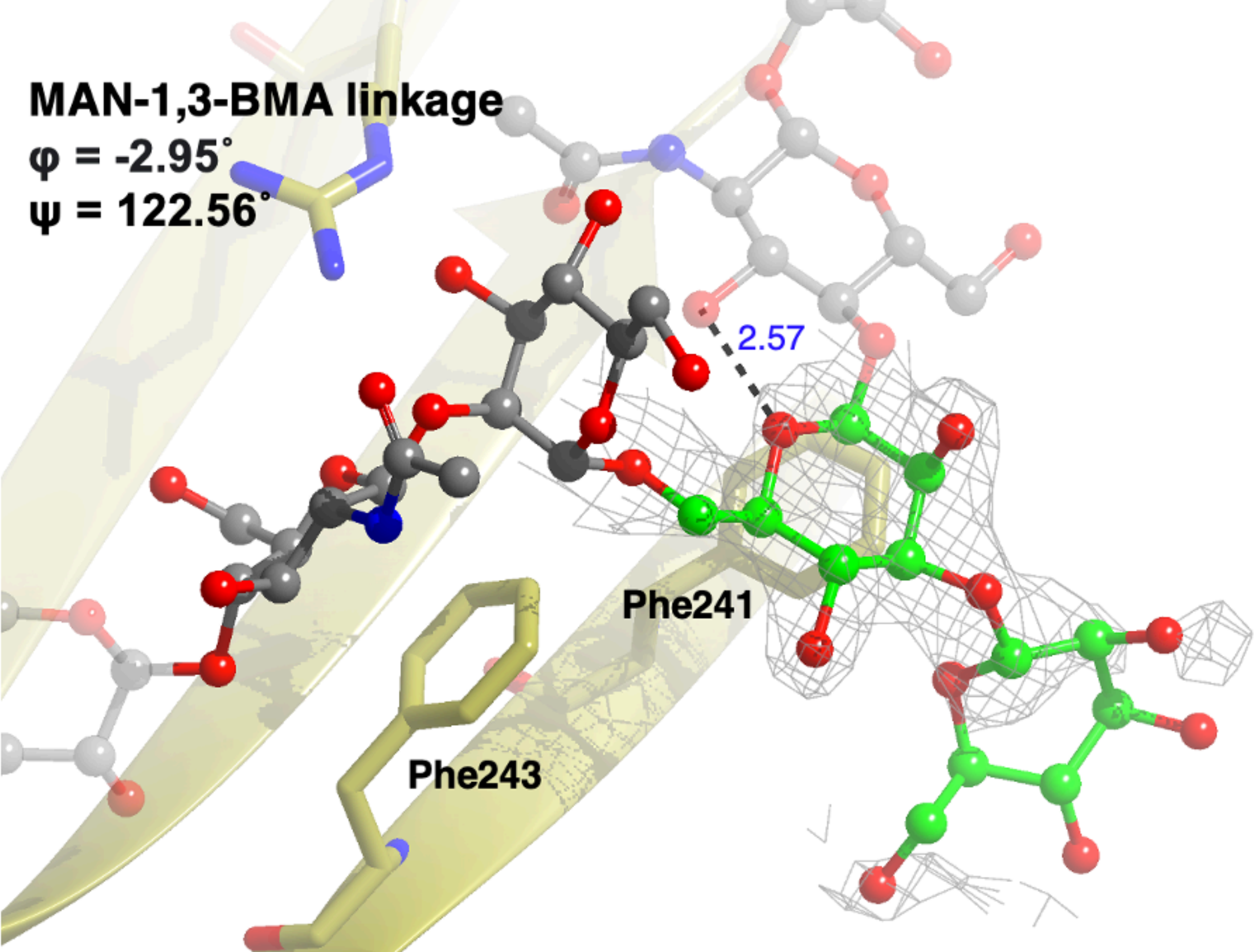

Detection of XH-Pi interactions

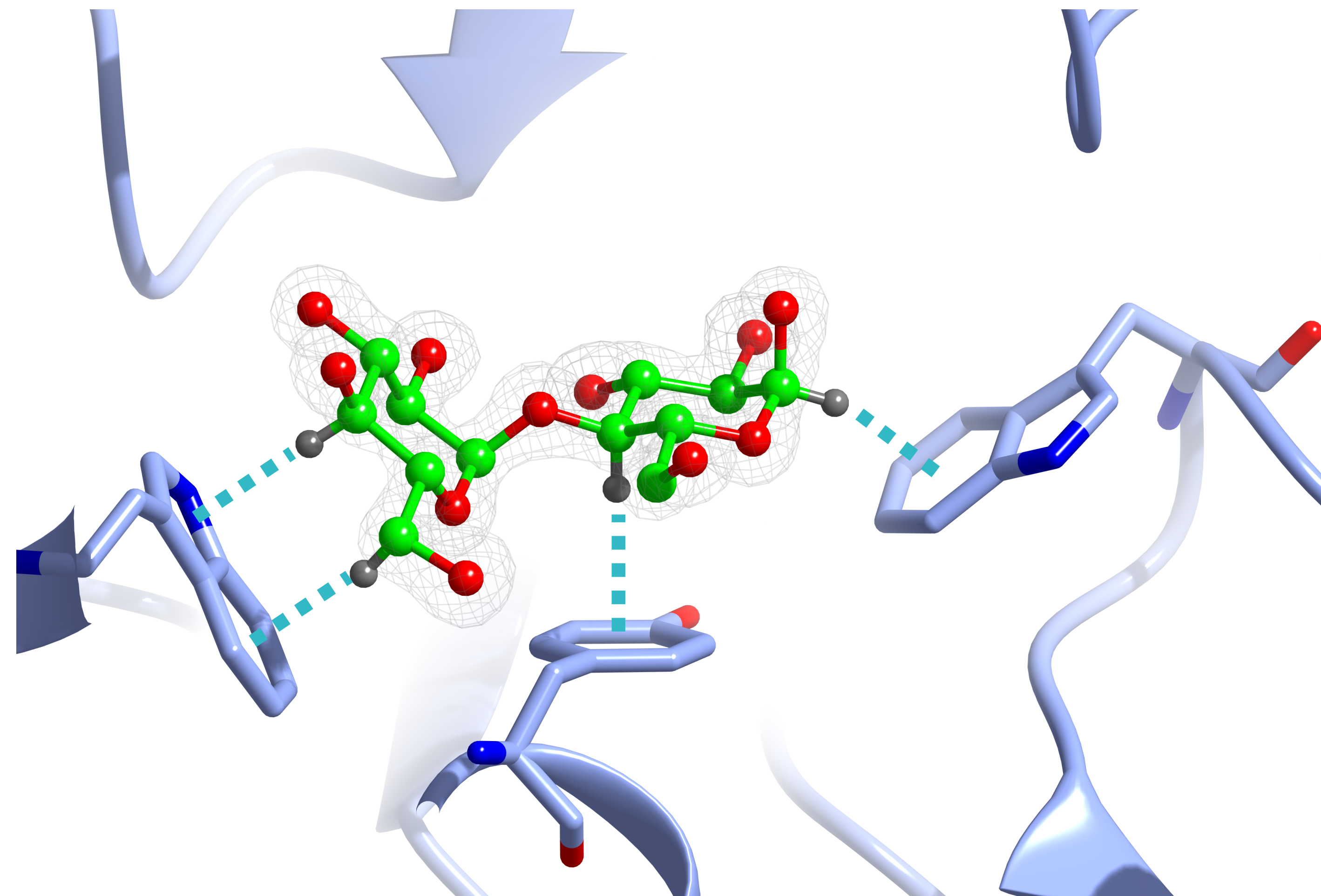
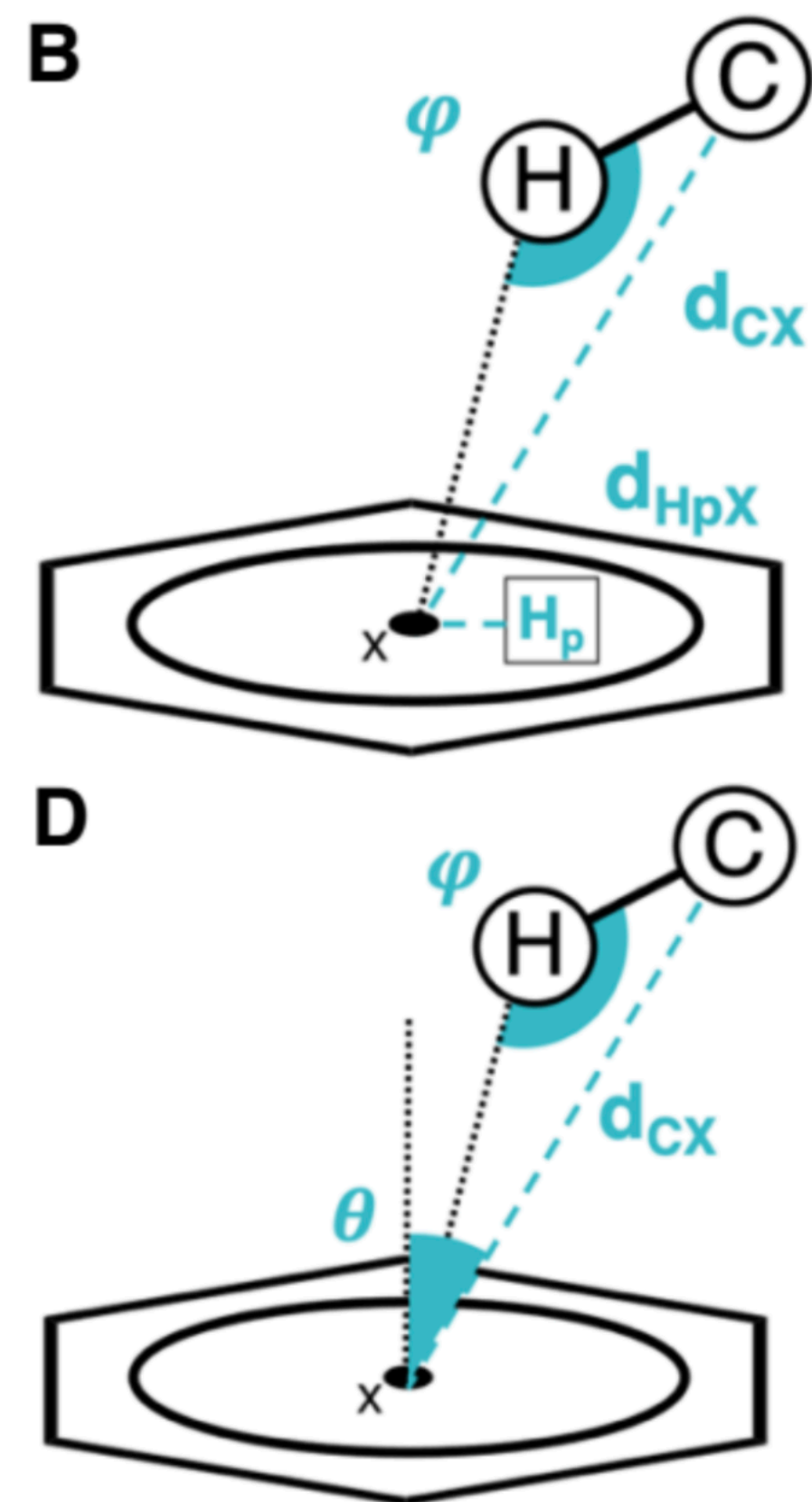
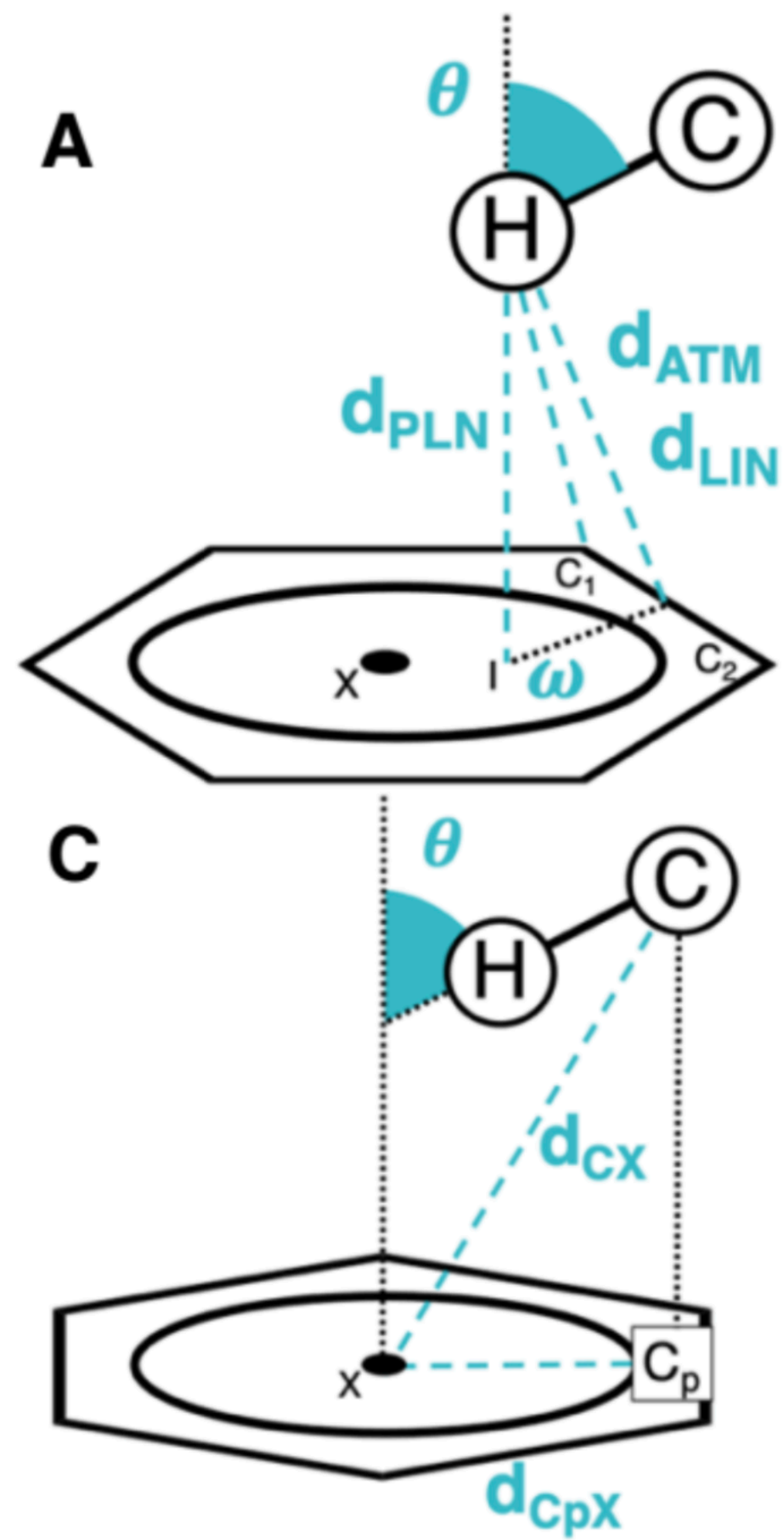

Conclusions

- **Glycan composition**

- Always make sure your glycans **match biosynthetic pathways**
- Privateer will check your glycans against glycomics data and suggest **alternatives** if there are inconsistencies

- **Ring conformation**

- High-energy puckers are **almost never true**
- These are usually the result of **modelling errors** or **refinement against poor density**, and need to be corrected

- **Glycosidic link torsions**

- Modelling errors may force links into surprising conformations
- Not all standout conformations are wrong – **check interactions!**

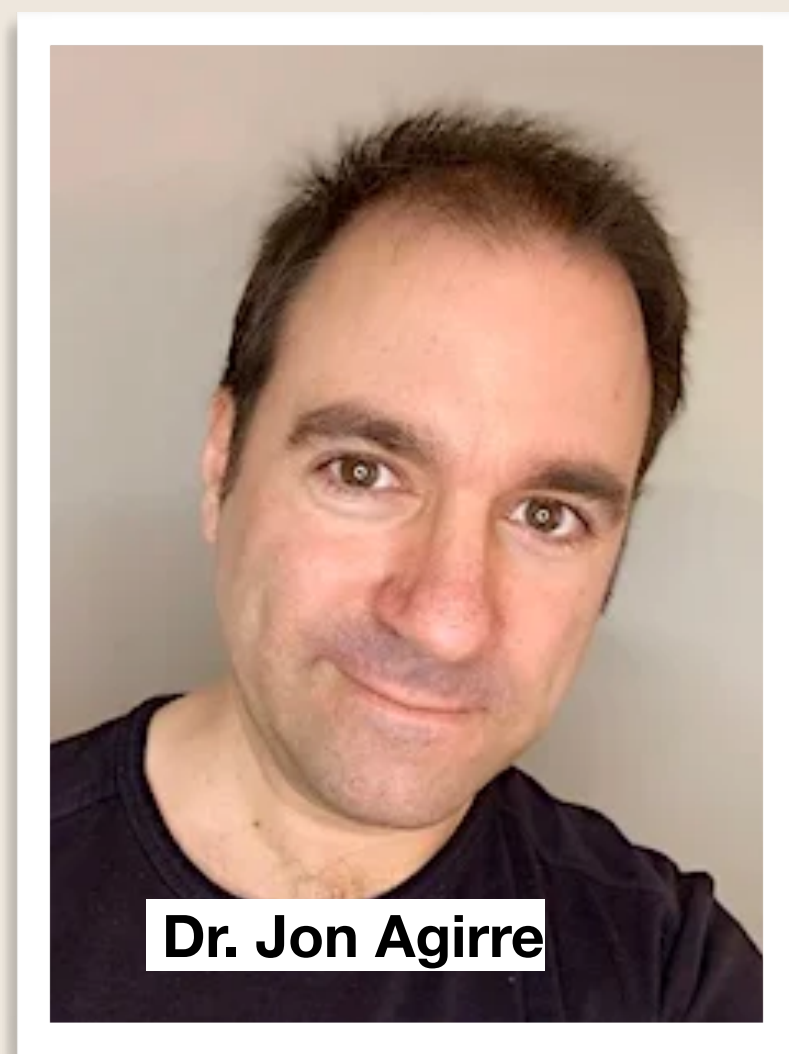

Dr. Jon Agirre

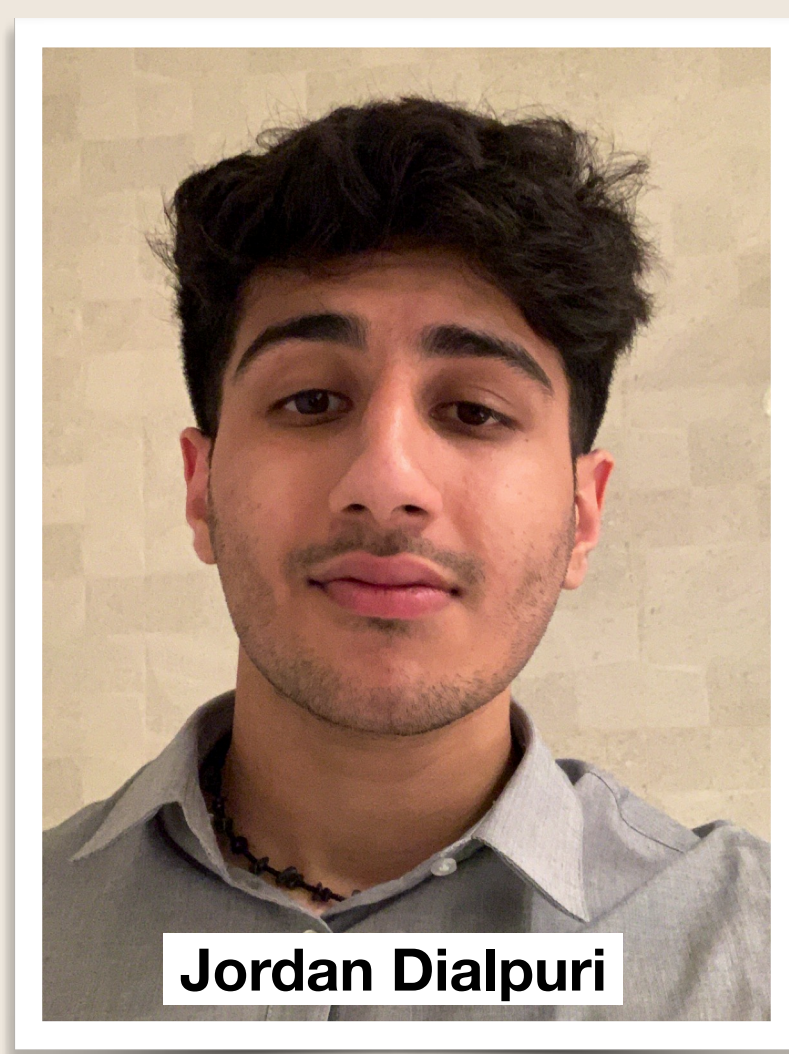

Jordan Dialpuri



Dr. Lou Holland



Lucy Schofield

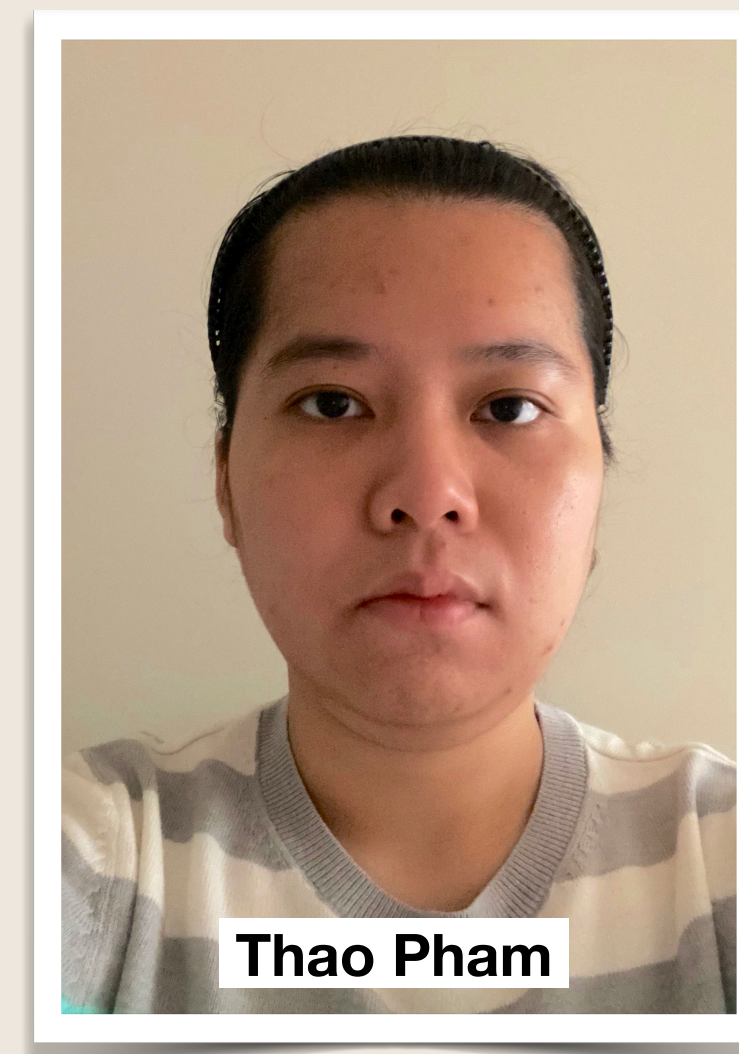

Thao Pham

Glycojones team



Dr. Manal Alzahrani



Dr. Haroldas Bagdonas

Acknowledgements

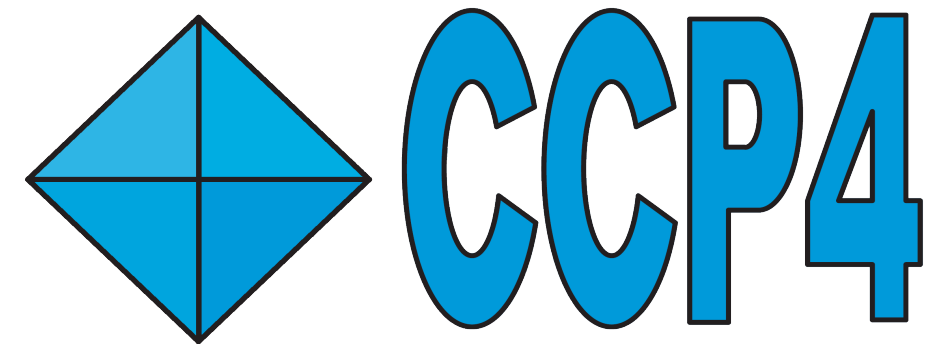

Collaborators

Garib Murshudov (MRC-LMB, Cambridge)

Robbie Joosten (NKI, The Netherlands)

Robert Nicholls (MRC-LMB, Cambridge)

Elisa Fadda (Maynooth University, Ireland)

Elena Seiradake (University of Oxford)

Martin Frank (Biognos, Sweden)

Frédérique Lisacek (SIB, Switzerland)

Sameer Velankar & Gerard Kleywegt (PDBe & AFDB)

CCP4 & CCP-EM core teams

Stock figures: Wikimedia Commons

